

PRODUCT SPECIFICATION

PART NUMBER #REV: QP-101WSVGATLLC1D#00
 DESCRIPTION: TFT 10.1"wide 1024*600 TN LVDS 400CD
 With Pcap Black 2 mm Cover Glass USB-I2C interface

- () Preliminary Specification
- (V) Approved Specification

Customer Name:	
Signature:	Date:

QiteX Advanced Display Solution	
PREPARED BY	REVIEWED BY
<i>Natalie</i>	<i>David</i>

CONTENTS

Table of Content

1 Precautions and Warranty	4
1.1 Precaution	4
1.2 Warranty	4
2 GENERAL DESCRIPTION.....	5
2.1 General Specifications.....	5
3 Absolute Maximum Ratings.....	6
3.1 Absolute Ratings of Environment	6
3.2 Electrical Absolute Ratings	6
3.2.1 DC Characteristics.....	6
3.2.2 BLU DC Characteristic	6
4 BLOCK DIAGRAM	8
5 PIN CONNECTIONS.....	9
5.1 Pin Definition	9
6. AC CHARACTERISTICS	11
6.1 LVDS mode AC electrical characteristics	11
6.2 Data input format	13
7. Power On/Off Sequence	14
8. OPTICAL CHARACTERISTIC.....	16
B. Touch Screen specification.....	19
B-1. Environmental Specification	19
B-2. Mechanical Specification	19
B-3. USB Type Controller.....	19
9. OUTLINE DRAWING.....	21

1 Precautions and Warranty

1.1 Precaution

- 1.1.1 Do not apply rough force such as bending or twisting to the module during assembly.
- 1.1.2 To assemble or install module into user's system can be only in clean working areas. The dust and oil may cause electrical short or worsen the polarizer.
- 1.1.3 Use a soft dry cloth without chemicals for cleaning, because the surface of polarizer is very soft and easily scratched.
- 1.1.4 It's not permitted to have pressure or impulse on the module because the LCD panel and Backlight will be damaged.
- 1.1.5 Always follow the correct power sequence when LCD module is connecting and operating. This can prevent damage to the CMOS LSI chips during latch-up.
- 1.1.6 Do not pull the I/F connector in or out while the module is operating.
- 1.1.7 Do not disassemble the module, or insert anything into the Backlight unit
- 1.1.8 It is dangerous that moisture come into or contacted the LCD module, because moisture may damage LCD module when it is operating.
- 1.1.9 High temperature or humidity may reduce the performance of module. Please store LCD module
- 1.1.10 within the specified storage conditions.
- 1.1.11 The response time will become slowly below lower temperature.
- 1.1.12 Do not keep same pattern in a long period of time. It may cause image sticking on LCD.
- 1.1.13 Display may change color with different temperature.
- 1.1.14 The Module should be kept into anti-static bag or other containers resistant to static for storage.
- 1.1.15 If the liquid crystal material leaks from the panel, it should be kept away from the eyes or mouth. In case of contact with hands, skin or clothes, it has to be washed away thoroughly with soap.
- 1.1.16 After the module's end of life, it is not harmful in case of normal operation and storage.

1.2 Warranty

- 1.2.1 Our warranty liability is limited to repair and/or replacement. We will not be responsible for any consequential loss.
- 1.2.2 If possible, we suggest customer to use up all modules in six months. If the module storage time over twelve months, we suggest that recheck it before the module be used.

2 GENERAL DESCRIPTION

The specification is a color active matrix thin film transistor (TFT) liquid crystal display (LCD) that uses amorphous silicon TFT as a switching device. This product is composed of a TFT-LCD panel, driver ICs and a backlight unit.

2.1 General Specifications

Features	Details	Unit
Display Size (Diagonal)	10.1" w	
LCD type	TN TFT	
Display Mode	Transmissive / Normally White	
Resolution	1024 RGB x 600	Pixels
View Direction	12 O'clock	Best Image
Gray Scale Inversion Direction	6 O'clock	
Module Outline	247(H) x 157.16(V) x 10 max.(T) (Note1)	mm
Active Area	222.72(H) x 125.28(V)	mm
Pixel Size	0.2175(H) x 0.2088(V)	mm
Pixel Arrangement	RGB Vertical stripe	
Polarizer Surface Treatment	Anti-glare	
Interface	6/8 bit LVDS Interface	
Display Colors	262K/16.7M	
With or Without Touch Panel	With	-
Weight	TBD	g

Note1: Exclusive posts, FFC/FPC tail etc.

3 Absolute Maximum Ratings

3.1 Absolute Ratings of Environment

$V_{SS}=0V, T_a=25^{\circ}C$

Item	Symbol	Min.	Max.	Unit
Supply Voltage	VCC LCD	-0.5	3.96	V
Storage temperature	T _{STG}	-30	+80	°C
Operating temperature	T _{OP}	-20	+70	°C

Note 1: If T_a below $50^{\circ}C$, the maximal humidity is 90%RH, if T_a over $50^{\circ}C$, absolute humidity should be less than 60%RH.

Note 2: The response time will be extremely slow when the operating temperature is around $-10^{\circ}C$, and the background will become darker at high temperature operating.

3.2 Electrical Absolute Ratings

3.2.1 DC Characteristics

Item	Symbol	Min.	Typ.	Max.	Unit
Digital Supply Voltage	VCC LCD	2.3	3.3	3.6	V
Differential input high threshold voltage	RxVTH	-	-	0.1	V
Differential input low threshold voltage	RxVTL	-0.1	-	-	V
Input voltage range (singled-end)	RxVIN	0	-	$VDD-1.2+ VID /2$	V
Differential input common mode voltage	RxVCM	$ VID /2$	-	$VCC-1.2$	V
Differential input voltage	$ VID $	0.2	-	0.6	
Current Consumption All Black	ICC	-	TBD	-	mA

Note 1: All of the voltage listed above are with respect to $GND=0V$

Note 2: Device is subject to be damaged permanently if stresses beyond those absolute maximum rating listed above.

3.2.2 BLU DC Characteristic

Item	Symbol	Min.	Typ.	Max.	Unit
BLU Supply Voltage	BLK VCC	-	5	7.5	V
Logic Low Threshold (EN,PWM)	VIL	-	-	0.8	V
Logic High Threshold (EN,PWM)	VIH	1.9	-	-	V
PWM Dimming Frequency	fDIM	100	-	30K	V
Pull Down Resistor (Both EN and PWM pins)	RPD	-	800	-	kΩ
LED working life($25^{\circ}C$)			40000		Hrs

Note1 : Led lifetime defined as follows: The final brightness is at 50% of original brightness.

The environmental conducted under ambient air flow, at $T_a=25\pm 2\text{ }^\circ\text{C}$, $60\%RH\pm 5\%$.

Typical operating life time is estimated data, led power dissipation is evaluated by led supplier.

The LED brightness is controlled by pulse-width-signal at the PWM pin. The high duration of the PWM signal is replicated as the turn-on duration of LED current flow through CHx current-sink regulators. Dimming frequency is from 100Hz to 30KHz. Within this frequency range, screen flickering is avoided while dimming linearity is maintained. With proper output capacitors, the device is designed to minimize output AC ripple during PWM dimming.

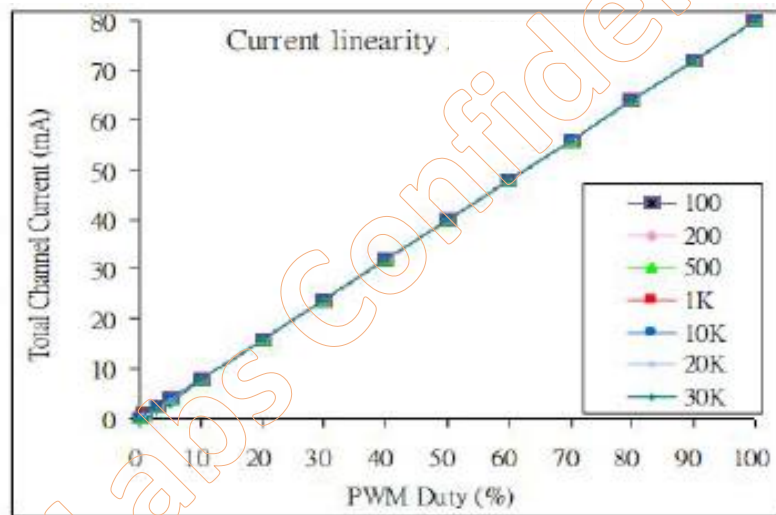

4 BLOCK DIAGRAM

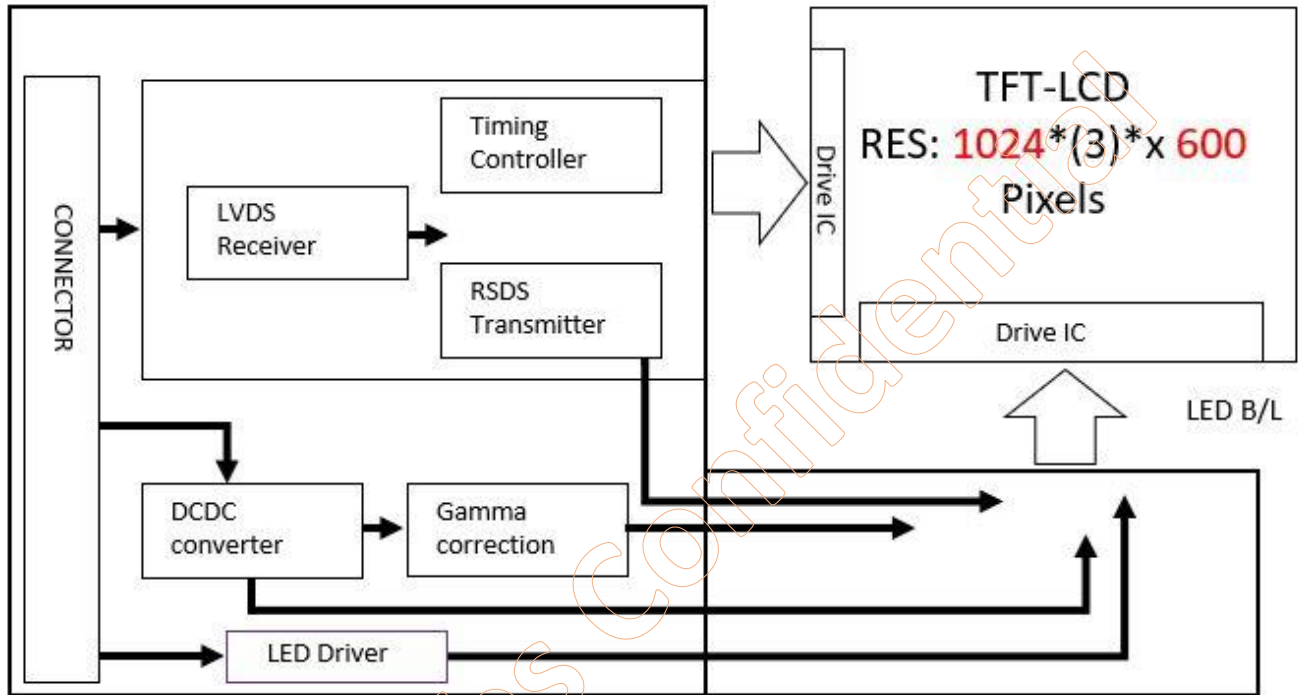

5 PIN CONNECTIONS

5.1 Pin Definition

Connector: 093G30-00001A-M4

No.	Symbol	Function
1	VCC LCD(3.3V)	Power Supply
2	VCC LCD(3.3V)	Power Supply
3	SEL 6/8	"L": 8bit LVDS interface "H":6bit LVDS interface
4	RX0-	-LVDS differential data input
5	RX0+	+LVDS differential data input
6	RX1-	-LVDS differential data input
7	RX1+	+LVDS differential data input
8	RX2-	-LVDS differential data input
9	RX2+	+LVDS differential data input
10	GND	Ground
11	RXCLK-	-LVDS differential clock input
12	RXCLK+	+LVDS differential clock input
13	RX3-	-LVDS differential data input
14	RX3+	+LVDS differential data input
15	GND	Ground
16	U/D	Horizontal inversion (Note1)
17	L/R	Vertical inversion (Note1)
18	NC	No connection
19	NC	No connection
20	NC	No connection
21	NC	No connection
22	GND	Ground
23	NC	No connection
24	NC	No connection
25	NC	No connection
26	NC	No connection
27	BLK VCC (5.0-7.5V)	Power for LED backlight
28	BLK VCC (5.0-7.5V)	Power for LED backlight
29	ENABLE	Chip Enable (Active High) for Boost Converter
30	PWM	Dimming Control Input

*Note1: U/D R/L Function Description

Scan Control Input		Scanning Direction
UPDN	SHLR	
GND	VCC	Left→Right, Up→Down(default)
GND	GND	Right→Left, Up→Down
VCC	VCC	Left→Right, Down→Up
VCC	GND	Right→Left, Down→Up

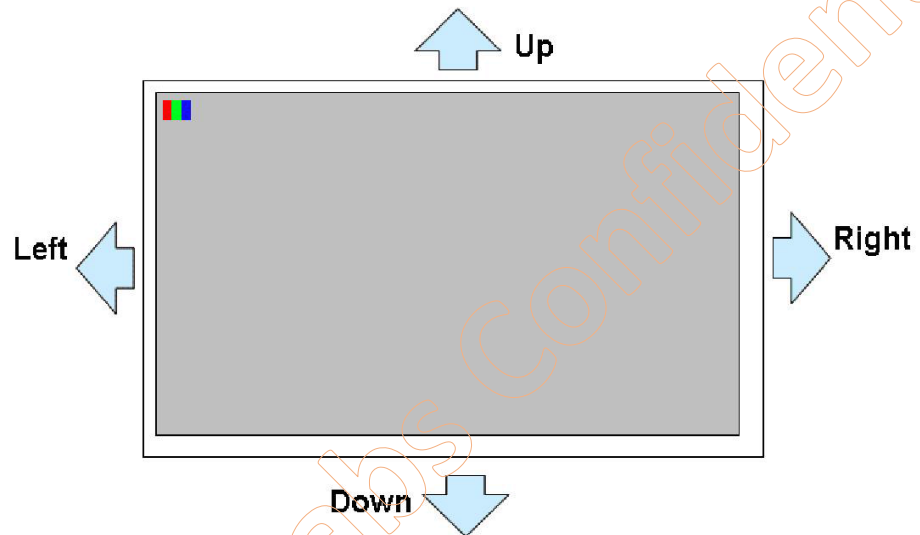

6. AC CHARACTERISTICS

6.1 LVDS mode AC electrical characteristics

Parameter	Symbol	Min	Typ	Max	Unit	Condition
Clock frequency	RxFCLK	20	-	71	MHz	
Input data skew margin	TRSKM	500			pS	IVI _{DI} = 400Mv RxVCM = 1.2V RxFCLK = 71MHz
Clock high time	TLVCH		$4/(7 \cdot RxFCLK)$		ns	
Clock low time	TLVCL		$3/(7 \cdot RxFCLK)$		ns	
PLL wake-up time	T _{enPLL}			150	us	
Modulation Frequency	SSCMF	23	-	93	KHz	
Modulation Rate	SSCMR	-	-	+/-3	%	LVDS clock=71MHz center spread

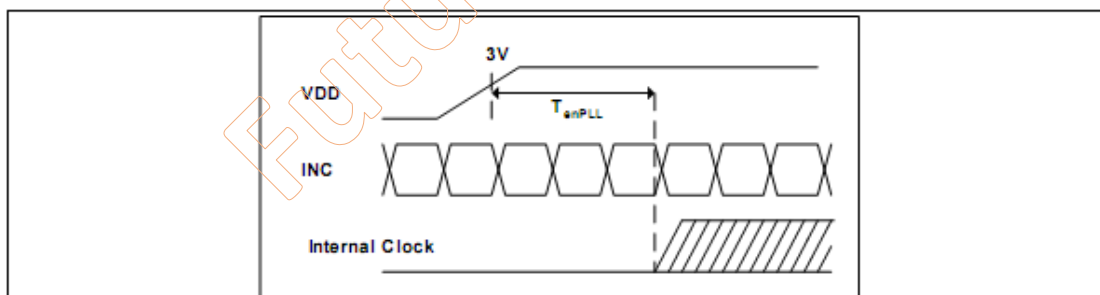
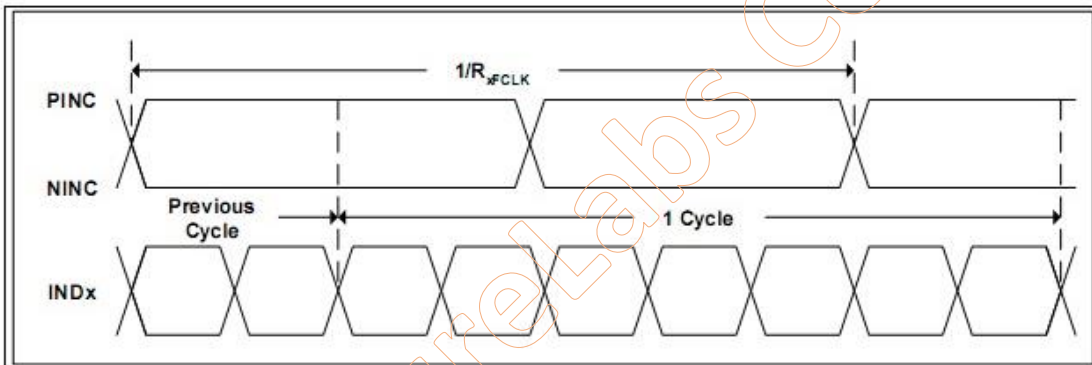

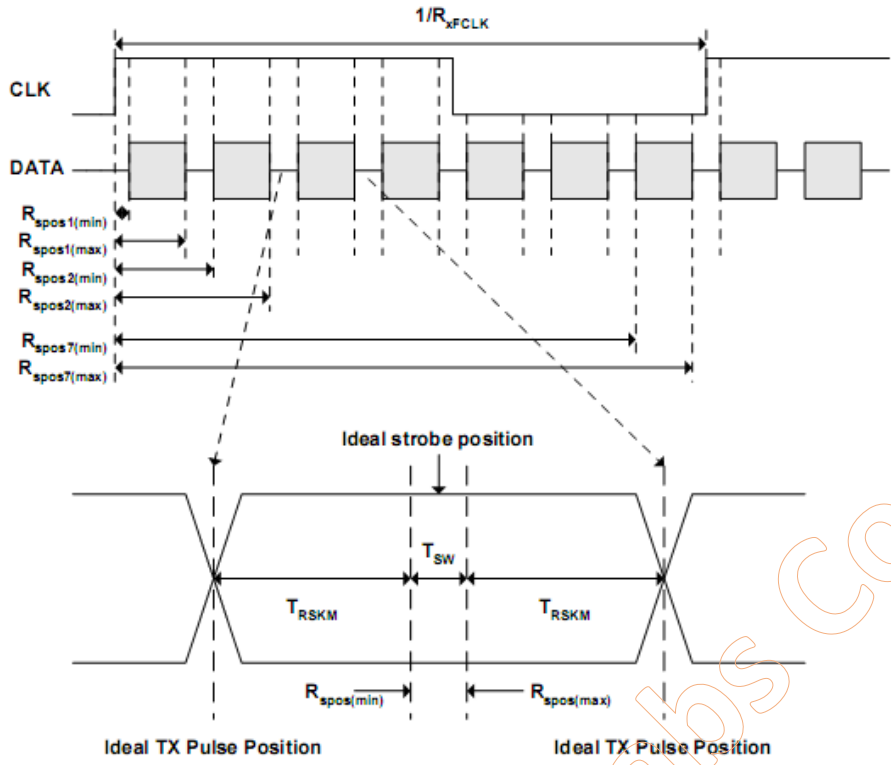

T_{RSKM} : Receiver strobe margin
 R_{spos} : Receiver strobe position
 T_{SW} : Strobe width (Internal data sampling window)

FutureLabs Confidential

6.2 Data input format

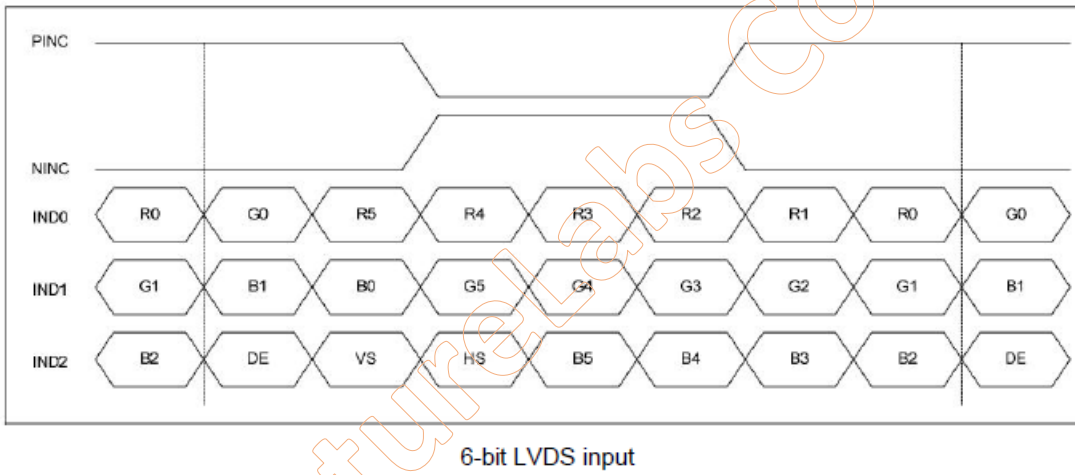
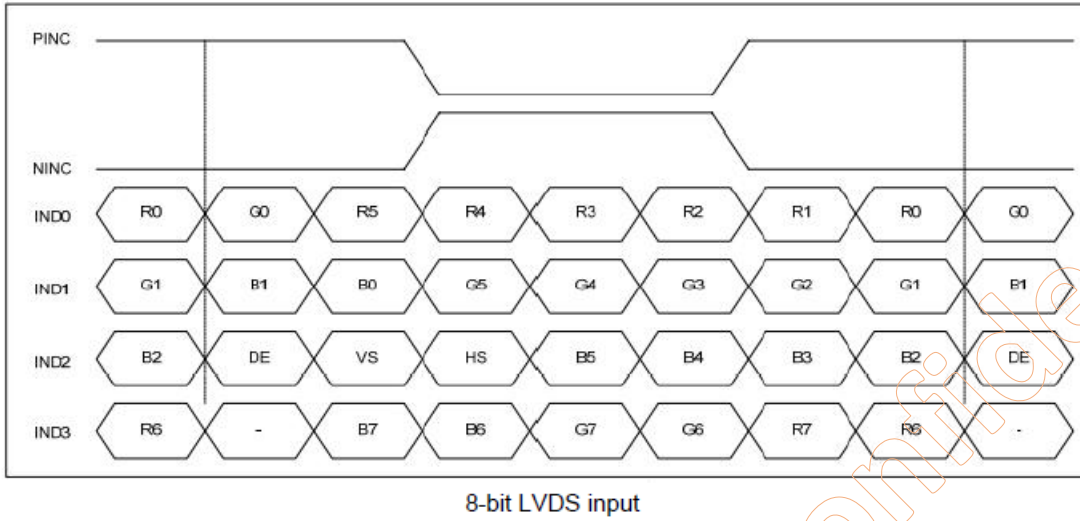

7. Power On/Off Sequence

To prevent the device damage from latch up, the power on/off sequence shown below must be followed.

Power on: VDD, GND → AVDD, AGND → V1 to V14
 Power off: V1 to V14 → AVDD, AGND → VDD, GND

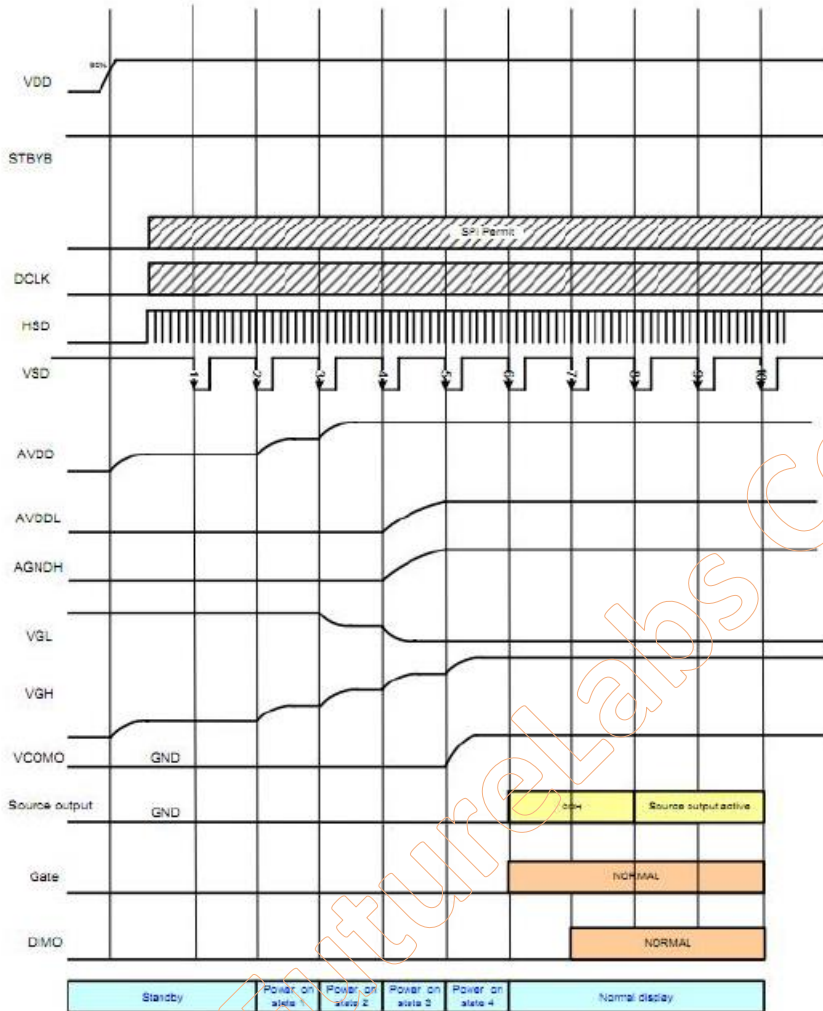

Power on timing sequence

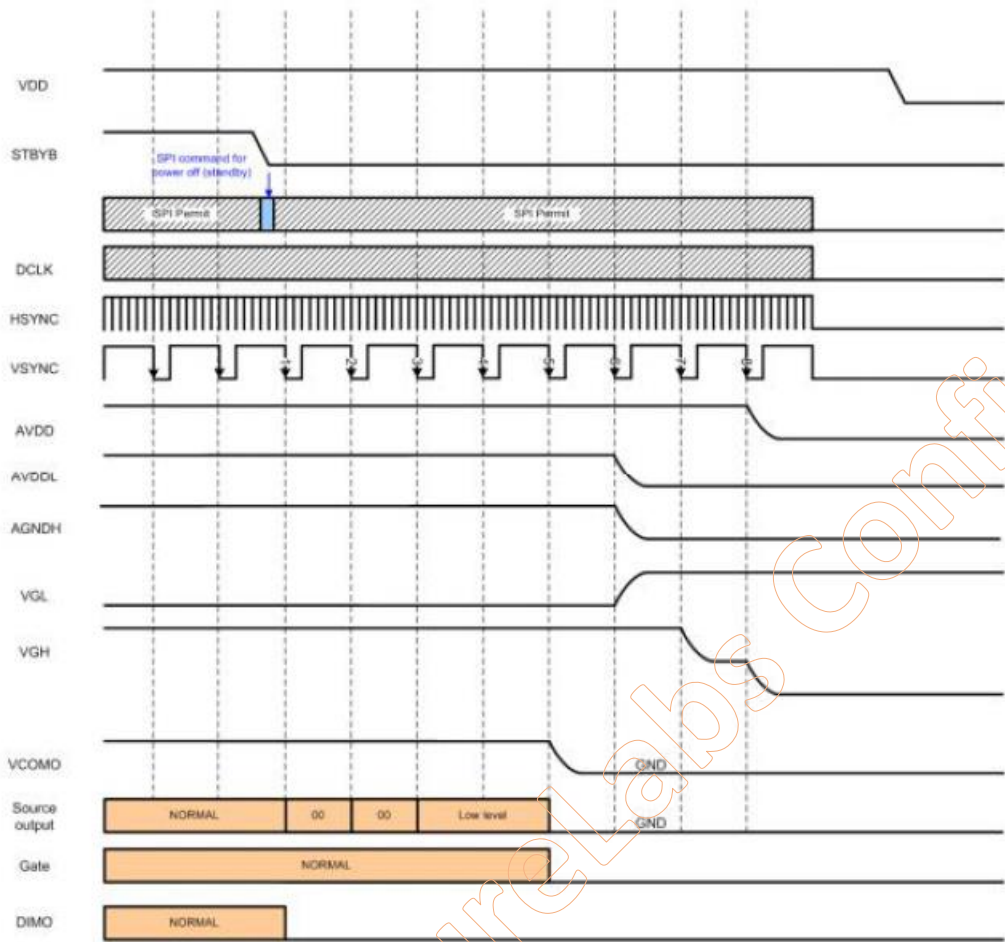

Power off timing sequence

8. OPTICAL CHARACTERISTIC

Item		Symbol	Condition	Specification			Unit	Note
				Min.	Typ.	Max.		
Viewing Angle	Horizontal	$\theta X+$	Center CR \geq 10	60	70	-	Deg.	Note 2
		$\theta X-$		60	70	-		
	Vertical	$\phi Y+$		50	60	-		
		$\phi Y-$		60	70	-		
NTSC Ratio(Gamut)				-	52	-	%	
Contrast ratio		CR	Normally viewing angle $\theta X = \phi Y = 0^\circ$	400	450	-		Note 3
Luminance on TFT ($I_f=20\text{mA/LED}$)		Lv		320	400	-	cd/m ²	
Response time		TR+TF		-	8	-	ms	Note 4
Color Chromaticity	Red	XR		-	TBD	-	-	
		YR			TBD			
	Green	XG			TBD			
		YG			TBD			
	Blue	XB			TBD			
		YB			TBD			
	White	XW			TBD			
		YW			TBD			

Note 1: The method of optical measurement:

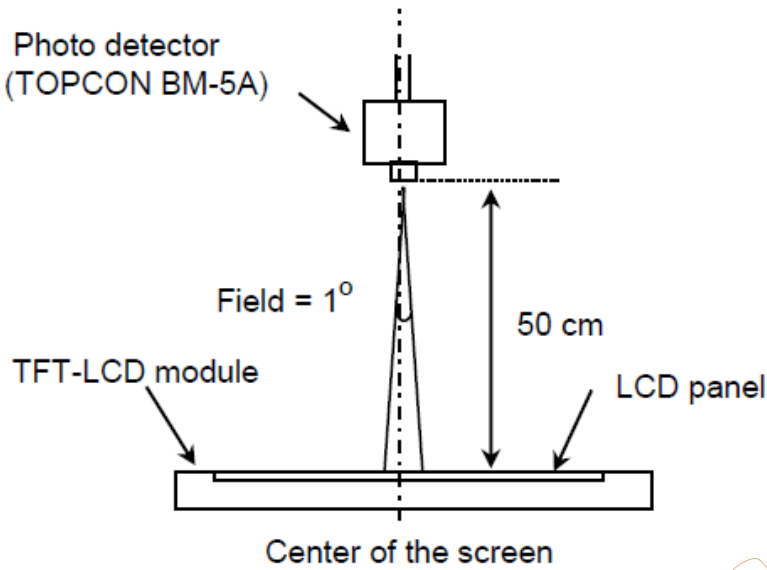

Note 2: Definition of Viewing Angles:

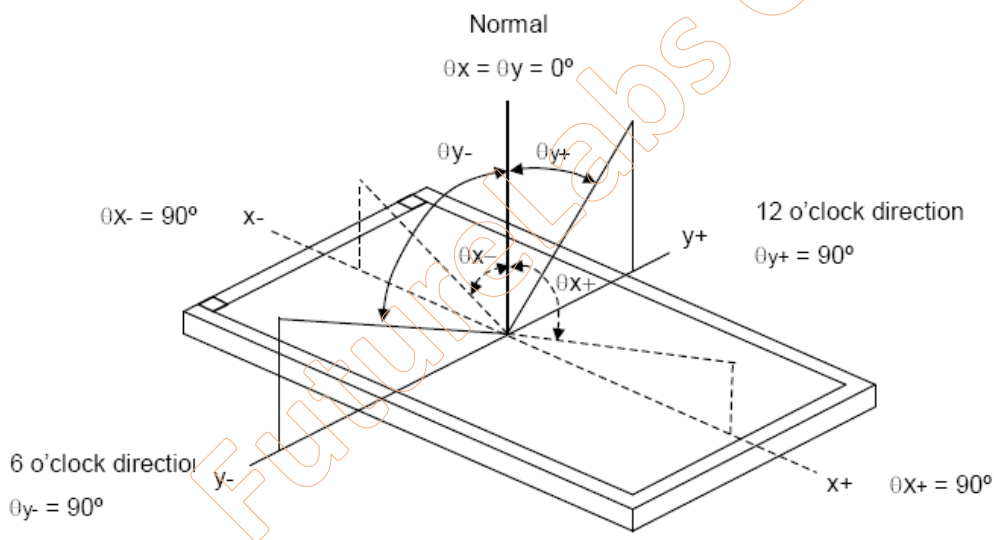

Note 3: Definition of Contrast ratio

Contrast is measured perpendicular to display surface in reflective and transmissive mode.

The measurement condition is:

Measuring Equipment	Eldim or Equivalent
Measuring Point Diameter	3mm//1mm
Measuring Point Location	Active Area centre point
Test pattern	A: All Pixels white
	B: All Pixel black
Contrast setting	Maximum

Definitions: CR (Contrast) = Luminance of White Pixel / Luminance of Black Pixel

Note 4: Definition of Response Time:

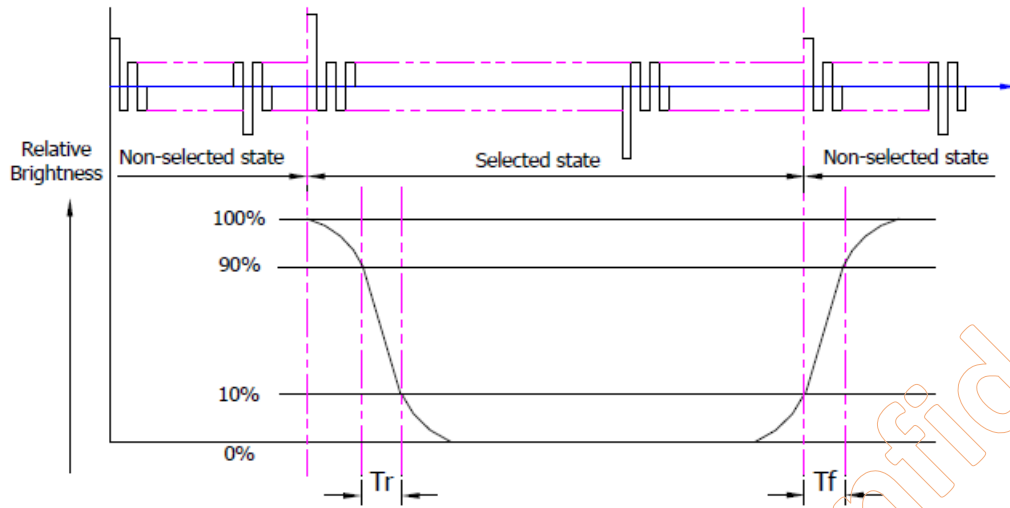

Note 5: Definition of Surface Luminance, Uniformity and Transmittance

Using the transmissive mode measurement approach, measure the white screen luminance of the display panel and backlight.

5.5.1. Surface Luminance: $LV = \text{average (LP1:LP9)}$

5.5.2. Uniformity = $\text{Minimal (LP1:LP9) / Maximal (LP1:LP9) * 100\%}$

5.5.3. Transmittance = $LV \text{ on LCD} / LV \text{ on Backlight} * 100\%$

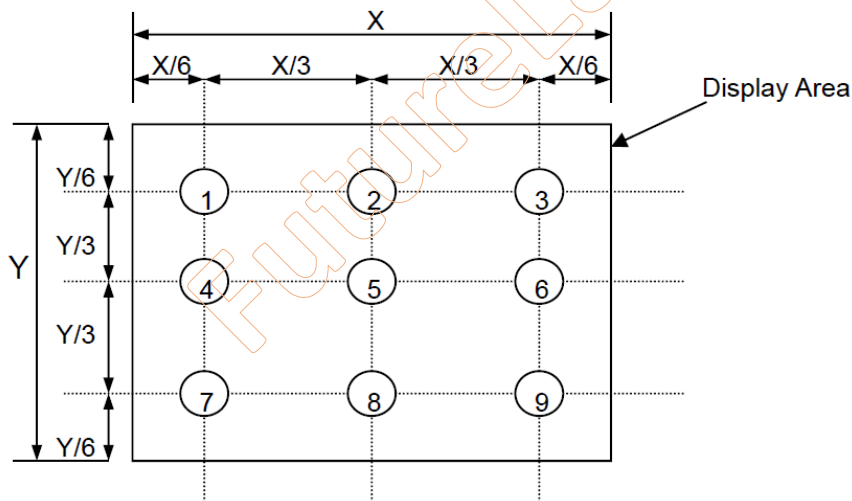

B. Touch Screen specification

B-1. Environmental Specification

Specification	Value
Operating Temperature	-20°C ~ 70°C
Storage Temperature	-30°C ~ 80°C
Operating Humidity	20% ~ 90%RH
Storage Humidity	10% ~ 90%RH

B-2. Mechanical Specification

Specification	Value
Operating Life (Finger input)	10 ⁷ times
Light Transmittance	>85% Min. (JIS K-7105) with glass
Surface hardness	6H
FPC Peeling Force	5N Max

B-3. USB-I2C Type Controller

Parameters	Features
Circuit Board Dimension	Refer to drawings
Channels of Panel	Based on Sensor Design
Input Voltage	5V for USB - 5V/3,3V (Min 3.2V) for I2C
Linearity(Note 1)	Single Line drawing accuracy : Up to 1pt +/- 1mm offset /10mm
	Single Touch (point) accuracy : Up to 1pt +/- 1mm
Interface	USB: 2.0(Below) Full Speed I2C:100K/400K Hz
Resolution	16384×16384 resolution
Power consumption(mA)	Active Mode: <50mA
	Idle Mode : <45mA
	Sleep Mode :<15mA
	(Operation Mode :Active Mode only)
Report rate(points/sec) Note(2)	> 100 Hz
Response time	Average < 25 ms

Note (1): Depending by Sensor design and other parameters, Refer to Windows 8 Logo regulation if need to follow min spec

Note (2): Report rate will vary by channel number, cover thickness, number of fingers and other parameter

FutureLabs Confidential

9. OUTLINE DRAWING

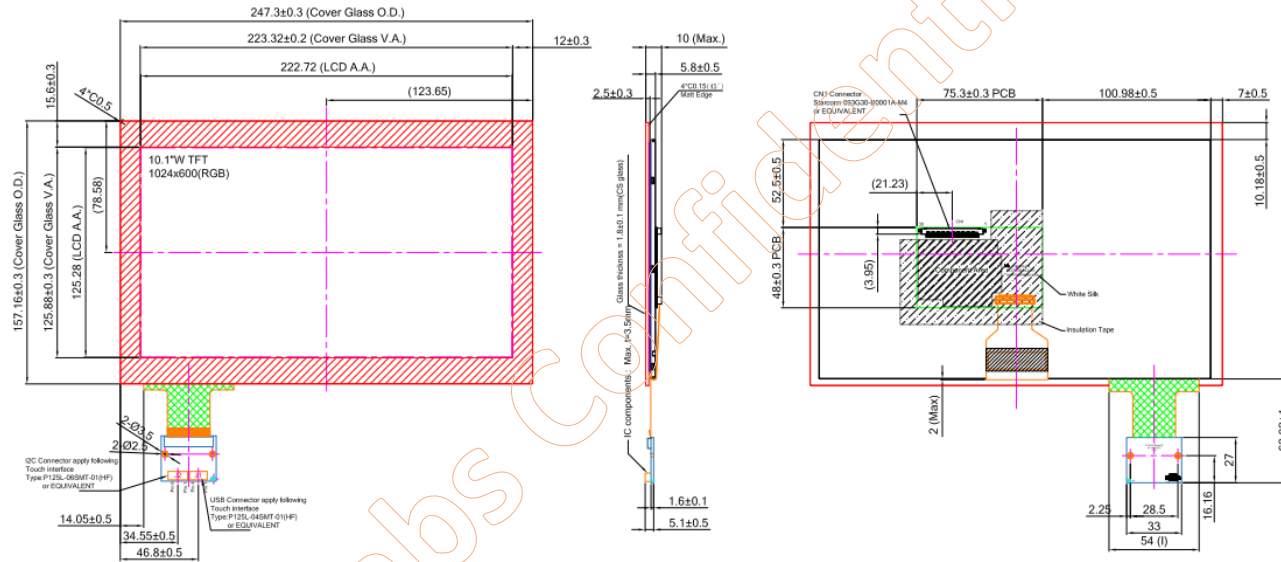

J1: Pin Define for USB 4 pin	
Pin 01	GND
Pin 02	D-
Pin 03	D+
Pin 04	VDD(5V)

J2: Pin Define for I2C 6 pin	
Pin 01	GND
Pin 02	SDA
Pin 03	SCL
Pin 04	VDD(5V) Pin (3.3V-5V)
Pin 05	INT
Pin 06	RST

Circuit Diagram (LED 3X10=30)

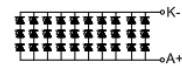

- NOTES:
 1. General tolerance are ±0.5mm
 2. ROHS Complied

CN1 Pin Define					
NO.	PIN Define	NO.	PIN Define	NO.	PIN Define
1	VCC	11	RXCK-	21	NC
2	VCC	12	RXCK+	22	GND
3	SEL 6/8	13	RX3-	23	NC
4	RX0-	14	RX3+	24	NC
5	RX0+	15	GND	25	NC
6	RX1-	16	U/D	26	NC
7	RX1+	17	L/R	27	BLK VCC(5.0-7.5V)
8	RX2-	18	NC	28	BLK VCC(5.0-7.5V)
9	RX2+	19	NC	29	ENABLE
10	GND	20	NC	30	PWM

Customer Approval	Part Number # Rev.	QP-101WSVGATLLCTD #00