

Product Specification

Part Number #REV: FLD-121GML20PCCA1#00

Description: TFT 12.1" 1024*768 Full View One Channel LVDS 600CD +

Rocktouch Pcap 2mm Black USB /I2C

() Preliminary Specification

(V) Approved Specification

Customer Name:	
Signature:	Date:

PREPARED BY	REVIEWED BY
<i>Mia Huang</i>	<i>David</i>

Revision History

Version	Date	Page	Description	Note
V1.0	2021/07/02		First Edition	
V1.1	2021/08/04		Update ME page	

FutureLabs Confidential

Table of Content

Product Specification	1
1. GENERAL DESCRIPTION	4
1.1 Description	4
1.2 Product Summary	4
2. ABSOLUTE MAXIMUM RATING	5
2.1 Electrical Absolute Rating	5
2.2 Environment Absolute Rating	5
3. ELECTRICAL CHARACTERISTICS	6
3.1 LCD Electrical Specification	6
3.2 Backlight Unit	8
4. COLOR DATA INPUT ASSIGNMENT	9
5. INTERFACE TIMING	11
5.1 INPUT SIGNAL TIMING SPECIFICATIONS	11
5.2 Power ON/OFF Sequence	12
5.3 The Input Data Format	13
5.4 Scanning Direction	14
6. INTERFACE PIN DESCRIPTION	15
6.1 LCM Connector PIN Assignment	15
6.2 BACKLIGHT UNIT(Converter connector pin)	16
7. BLOCK DIAGRAM	17
8. OPTICAL CHARACTERISTIC	18
B. Touch Screen specification	21
1. Environmental Specification	21
2. Mechanical Specification	21
3. Combo Type Controller	21
9. DIMENSION AND DRAWING	23
10. PRECAUTION AND PRODUCT HANDLING	24

1. GENERAL DESCRIPTION

1.1 Description

12.1" is a Color Active Matrix Liquid Crystal Display Module composed of a TFT LCD panel and LED backlight system. The screen format is intended to support the XGA, 1024x768 screen and 262K / 16.7 M colors.

1.2 Product Summary

The following items are summary on the table under Ta=25 °C condition:

No.	Item	Specification	Unit
1	Display Size	12.1"	Inch
2	Pixel Number	1024 (H) x 3(RGB)x 768 (V)	Pixels
3	Outline Dimension	281.8(W)x220.8(H)x11.45(D, max)	mm
4	Active Area	245.76 (H) x 184.32 (V)	mm
5	Pixel Pitch	0.24 x0.24	mm
6	Display Colors	262K /16.7M colors	
7	Pixel Arrangement	RGB vertical stripe	--
8	Display Mode	Full View / Normally Black	--
9	Electrical Interface	One Channel LVDS	--
10	Surface Treatment	Anti-Glare, 3H Anti-Glare	--
11	Brightness	600 (Typ.)	--
12	Contrast Ratio	1000 (Typ.)	cd/m2
13	Total Power Consumption (Typ)	Total 12.02	W

FutureLabs Confidential

2. ABSOLUTE MAXIMUM RATING

2.1 Electrical Absolute Rating

Item	Symbol	Values			Unit	Note
		Min	Typ	Max		
Logic/LCD Drive Voltage	VCC	-0.3	--	4	V	(1)
Converter Voltage	V	-0.3	--	18	V	(1)(2)
Enable Voltage	EN	-	--	5.5	V	
Backlight Adjust	ASJ		--	5.5	V	

Note (1) Permanent damage to the device may occur if max values are exceeded.

Function operation should be restricted to the conditions described under normal operating conditions.

(2) Specified values are for input pin of LED light bar at $T_a = 25 \pm 2^\circ\text{C}$

2.2 Environment Absolute Rating

Item	Symbol	Values			Unit	Note
		Min	Typ	Max.		
Operating Temperature	T_{op}	-30		85	$^\circ\text{C}$	Note(1)(2)
Storage Temperature	T_{stg}	-40		90	$^\circ\text{C}$	

Note (1) : Temperature and relative humidity range is shown in the figure below.

(a) 90%RH Max. ($T_a \leq 40^\circ\text{C}$).

(b) Wet-bulb temperature should be 39°C Max. ($T_a > 40^\circ\text{C}$).

(c) No condensation.

Note(2) : The absolute maximum rating values of this product are not allowed to be exceeded at any times. The module should not be used over the absolute maximum rating value. It will cause permanently unrecoverable function fail in such an condition

3. ELECTRICAL CHARACTERISTICS

3.1 LCD Electrical Specification

Parameter	Symbol	Value			Unit	Note
		Min.	Typ.	Max.		
Logic/LCD Input Voltage	VCC	3.0	3.3	3.6	V	VDD=3.3V
LCD Rush Current	IRUSH	--	--	4	A	(2)
Power Supply Current	White		370	450	mA	(3) VDD=3.3V
	Black		300	380	mA	(3) VDD=3.3V
LCD Power consumption	PL	--	1.22	1.49	W	
LVDS differential input voltage	VID	100	--	600	mV	
LVDS common input voltage	VICM	0.7	--	1.6	V	

Note (1) The assembly should be always operated within above ranges. Ta = 25 ± 2 °C

Note (2) Measurement Conditions:

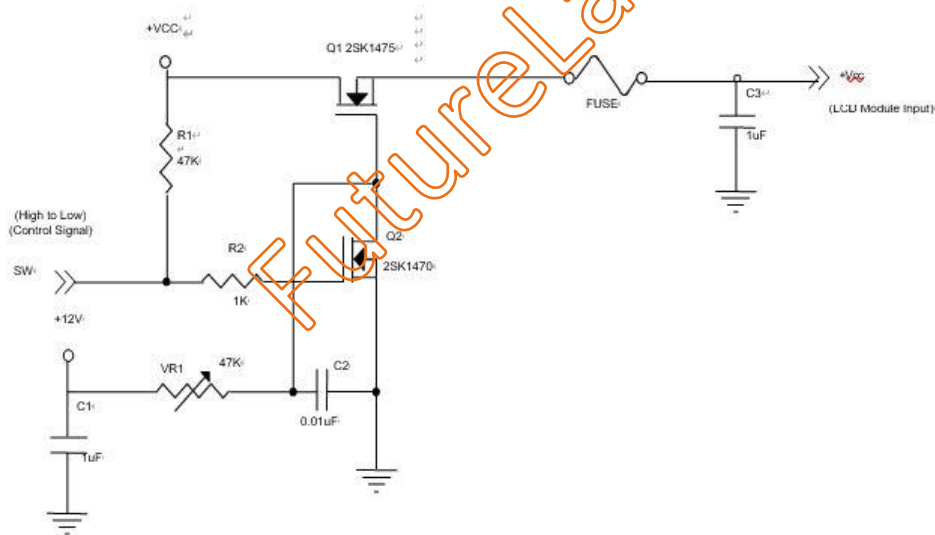

Vcc rising time is 470 μ s

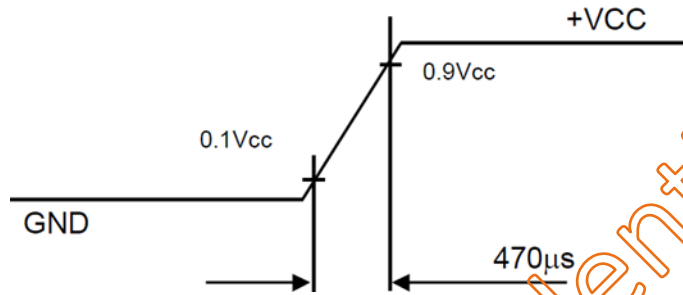

Note (3) The specified power supply current is under the conditions at $V_{cc} = 3.3V$, $T_a = 25 \pm 2 \text{ }^\circ\text{C}$, $f_v = 60 \text{ Hz}$, whereas a power dissipation check pattern below is displayed.

a. White Pattern

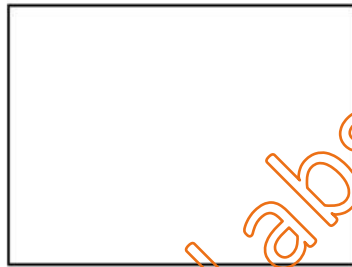

Active Area

b. Black Pattern



Active Area

3.2 Backlight Unit

Parameter guideline for LED driving is under stable conditions at 25°C (Room Temperature):

Symbol	Parameter		Min.	Typ.	Max.	Unit	Remark
Vi	Converter Power Supply Voltage		10.8	12.0	13.2	V	
Virp	Converter Power Supply Ripple Voltage				500	mv	
li	Converter Power Supply Current			0.9	1.07	A	Vi=12V(100% Duty)
Iirush	Converter Inrush Current				3.0	A	Vi rising time=10ms(Vi=12V)
PBL	Backlight Power Consumption			10.8	12.8	W	Vi = 12V(Duty 100%)
BLON	EN Control Level	Backlight on	2.5	3.3	5.0	V	
		Backlight off	0	--	0.3	V	
E_PWM	PWM Control Level	High Level	2.5	3.3	5.0	V	
		Low Level	0	--	0.15	V	
VNoise	PWM Noise Range				0.1	V	
--	PWM Control Duty Ratio				100	%	@200Hz
fpwm	PWM Control Frequency		190	200	20k	Hz	(3)
LL	LED Lifetime		50,000	--	-	Hrs	(2)

Note (1) LED current is measured by utilizing a high frequency current meter as shown below:

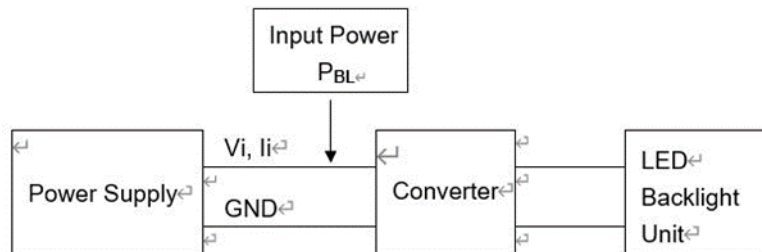

Note (2) The lifetime of LED is estimated data and defined as the time when it continues to operate under the conditions at $T_a = 25 \pm 2 \text{ }^\circ\text{C}$ and Duty 100% until the brightness becomes $\leq 50\%$ of its original value.

Operating LED at high temperature condition will reduce lifetime and lead to color shift.

Note (3) At 200Hz PWM control frequency , duty ratio range is restricted from 1% to 100%, When PWM control frequency is 20kHz, duty ratio range is restricted from 10% to 100%.

4. COLOR DATA INPUT ASSIGNMENT

The brightness of each primary color (red, green and blue) is based on the 6-bit gray scale data input for the color. The higher the binary input, the brighter the color. The table below provides the assignment of color versus data input

Color		Data Signal																	
		Red						Green						Blue					
		R5	R4	R3	R2	R1	R0	G5	G4	G3	G2	G1	G0	B5	B4	B3	B2	B1	B0
Basic Colors	Black	0	0	0	0	0	0	0	0	0	0	0	0	0	0	0	0	0	0
	Red	1	1	1	1	1	1	0	0	0	0	0	0	0	0	0	0	0	0
	Green	0	0	0	0	0	0	1	1	1	1	1	1	0	0	0	0	0	0
	Blue	0	0	0	0	0	0	0	0	0	0	0	0	1	1	1	1	1	1
	Cyan	0	0	0	0	0	0	1	1	1	1	1	1	1	1	1	1	1	1
	Magenta	1	1	1	1	1	1	0	0	0	0	0	0	1	1	1	1	1	1
	Yellow	1	1	1	1	1	1	1	1	1	1	1	1	0	0	0	0	0	0
	White	1	1	1	1	1	1	1	1	1	1	1	1	1	1	1	1	1	1
Gray Scale Of Red	Red(0)/Dark	0	0	0	0	0	0	0	0	0	0	0	0	0	0	0	0	0	0
	Red(1)	0	0	0	0	0	1	0	0	0	0	0	0	0	0	0	0	0	0
	Red(2)	0	0	0	0	1	0	0	0	0	0	0	0	0	0	0	0	0	0

	Red(61)	1	1	1	1	0	1	0	0	0	0	0	0	0	0	0	0	0	0
	Red(62)	1	1	1	1	1	0	0	0	0	0	0	0	0	0	0	0	0	0
Red(63)	1	1	1	1	1	1	0	0	0	0	0	0	0	0	0	0	0	0	
Gray Scale Of Green	Green(0)/Dark	0	0	0	0	0	0	0	0	0	0	0	0	0	0	0	0	0	0
	Green(1)	0	0	0	0	0	0	0	0	0	0	0	1	0	0	0	0	0	0
	Green(2)	0	0	0	0	0	0	0	0	0	0	1	0	0	0	0	0	0	0

	Green(61)	0	0	0	0	0	1	1	1	1	1	0	1	0	0	0	0	0	0
	Green(62)	0	0	0	0	0	1	1	1	1	1	1	0	0	0	0	0	0	0
Green(63)	0	0	0	0	0	1	1	1	1	1	1	0	0	0	0	0	0	0	
Gray Scale Of Blue	Blue(0)/Dark	0	0	0	0	0	0	0	0	0	0	0	0	0	0	0	0	0	0
	Blue(1)	0	0	0	0	0	0	0	0	0	0	0	0	0	0	0	0	0	1
	Blue(2)	0	0	0	0	0	0	0	0	0	0	0	0	0	0	0	0	1	0

	Blue(61)	0	0	0	0	0	0	0	0	0	0	0	0	1	1	1	1	0	1
	Blue(62)	0	0	0	0	0	0	0	0	0	0	0	0	1	1	1	1	1	0
Blue(63)	0	0	0	0	0	0	0	0	0	0	0	0	1	1	1	1	1	1	

Note (1) 0: Low Level Voltage, 1: High Level Voltage

The brightness of each primary color (red, green and blue) is based on the 8-bit gray scale data input for the color. The higher the binary input, the brighter the color. The table below provides the assignment of color versus data input.

Color		Data Signal																							
		Red								Green								Blue							
		R7	R6	R5	R4	R3	R2	R1	R0	G7	G6	G5	G4	G3	G2	G1	G0	B7	B6	B5	B4	B3	B2	B1	B0
Basic Colors	Black	0	0	0	0	0	0	0	0	0	0	0	0	0	0	0	0	0	0	0	0	0	0	0	
	Red	1	1	1	1	1	1	1	0	0	0	0	0	0	0	0	0	0	0	0	0	0	0	0	
	Green	0	0	0	0	0	0	0	1	1	1	1	1	1	1	1	0	0	0	0	0	0	0	0	
	Blue	0	0	0	0	0	0	0	0	0	0	0	0	0	0	0	1	1	1	1	1	1	1	1	
	Cyan	0	0	0	0	0	0	0	1	1	1	1	1	1	1	1	1	1	1	1	1	1	1	1	
	Magenta	1	1	1	1	1	1	1	0	0	0	0	0	0	0	0	1	1	1	1	1	1	1	1	
	Yellow	1	1	1	1	1	1	1	1	1	1	1	1	1	1	1	0	0	0	0	0	0	0	0	
	White	1	1	1	1	1	1	1	1	1	1	1	1	1	1	1	1	1	1	1	1	1	1	1	
Gray Scale Of Red	Red(0) / Dark	0	0	0	0	0	0	0	0	0	0	0	0	0	0	0	0	0	0	0	0	0	0		
	Red(1)	0	0	0	0	0	0	1	0	0	0	0	0	0	0	0	0	0	0	0	0	0	0		
	Red(2)	0	0	0	0	0	1	0	0	0	0	0	0	0	0	0	0	0	0	0	0	0	0		
		
		
	Red(253)	1	1	1	1	1	0	1	0	0	0	0	0	0	0	0	0	0	0	0	0	0	0		
	Red(254)	1	1	1	1	1	1	0	0	0	0	0	0	0	0	0	0	0	0	0	0	0	0		
	Red(255)	1	1	1	1	1	1	1	0	0	0	0	0	0	0	0	0	0	0	0	0	0	0		
Gray Scale Of Green	Green(0) / Dark	0	0	0	0	0	0	0	0	0	0	0	0	0	0	0	0	0	0	0	0	0	0		
	Green(1)	0	0	0	0	0	0	0	0	0	0	0	0	0	0	1	0	0	0	0	0	0	0		
	Green(2)	0	0	0	0	0	0	0	0	0	0	0	0	0	1	0	0	0	0	0	0	0	0		
		
		
	Green(253)	0	0	0	0	0	0	0	1	1	1	1	1	1	0	1	0	0	0	0	0	0	0		
	Green(254)	0	0	0	0	0	0	0	1	1	1	1	1	1	1	0	0	0	0	0	0	0	0		
	Green(255)	0	0	0	0	0	0	0	1	1	1	1	1	1	1	1	0	0	0	0	0	0	0		
Gray Scale Of Blue	Blue(0) / Dark	0	0	0	0	0	0	0	0	0	0	0	0	0	0	0	0	0	0	0	0	0	0		
	Blue(1)	0	0	0	0	0	0	0	0	0	0	0	0	0	0	0	0	0	0	0	0	0	1		
	Blue(2)	0	0	0	0	0	0	0	0	0	0	0	0	0	0	0	0	0	0	0	0	0	1		
		
		
	Blue(253)	0	0	0	0	0	0	0	0	0	0	0	0	0	0	0	1	1	1	1	1	1	0		
	Blue(254)	0	0	0	0	0	0	0	0	0	0	0	0	0	0	0	1	1	1	1	1	1	0		
	Blue(255)	0	0	0	0	0	0	0	0	0	0	0	0	0	0	0	1	1	1	1	1	1	1		

Note (1) 0: Low Level Voltage, 1: High Level Voltage

5. INTERFACE TIMING

5.1 INPUT SIGNAL TIMING SPECIFICATIONS

The input signal timing specifications are shown as the following table and timing diagram.

Signal	Item	Symbol	Min.	Typ.	Max.	Unit	Note
DCLK	Frequency	Fc	57.5	64.9	74.4	MHZ	
Vertical Active Display Term	Total	Tv	774	806	848	Th	Tv=Tvd+Tvb
	Display	Tvd	-	768	-	Th	-
	Blank	Tvb	6	38	80	Th	-
Horizontal Active Display Term	Total	Th	1240	1344	1464	Tc	Th=Thd+Thb
	Display	Thd	-	1024	-	Tc	-
	Blank	Thb	216	320	440	Tc	-

Note (1) Since this assembly is operated in DE only mode, Hsync and Vsync input signals should be set to low logic level. Otherwise, this assembly would operate abnormally.

Frame rate is 60Hz

The Tv(Tvd+Tvb) must be integer, otherwise, this module would operate abnormally.

INPUT SIGNAL TIMING DIAGRAM

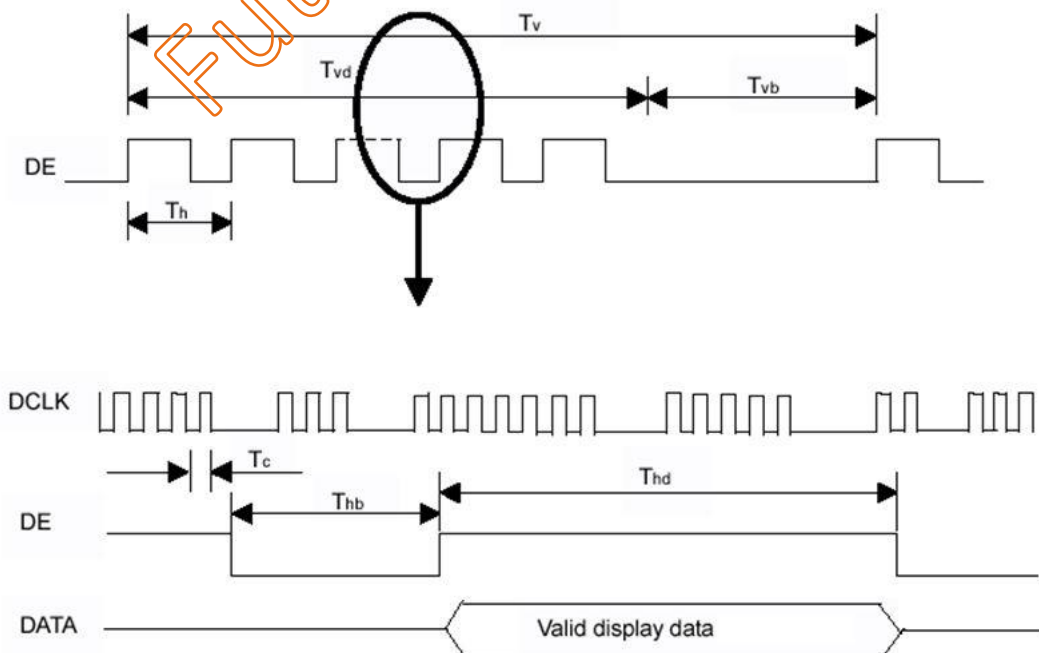

5.2 Power ON/OFF Sequence

VDD power and lamp on/off sequence is as below. Interface signals are also shown in the chart. Signals from any system shall be Hi-Z state or low level when VDD is off.

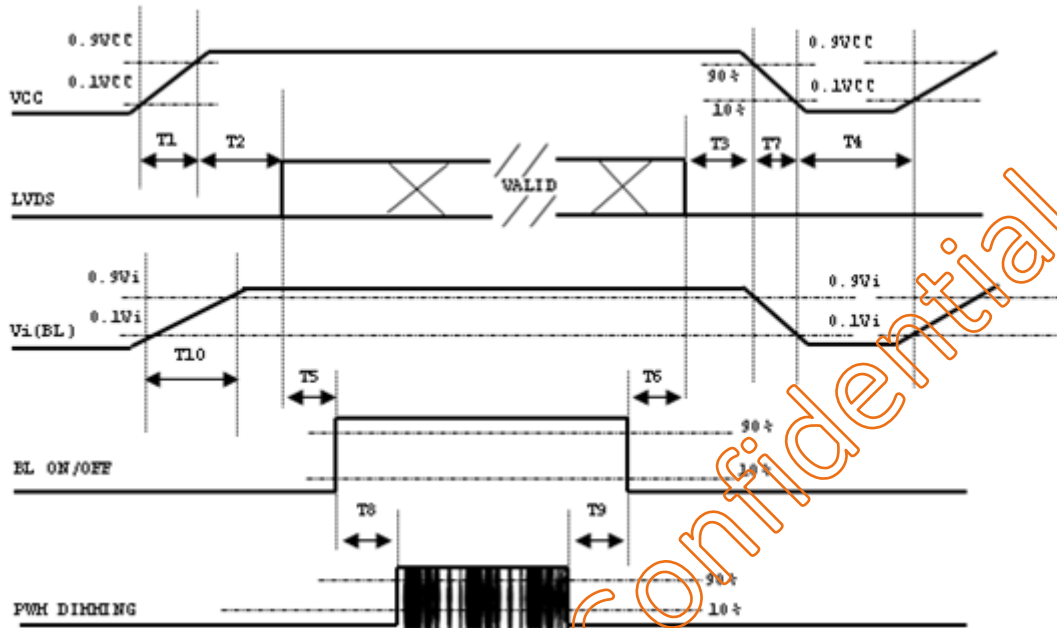

Note (1) Please avoid floating state of interface signal at invalid period.

Note (2) When the interface signal is invalid, be sure to pull down the power supply of LCD VCC to 0 V.

Note (3) The Backlight converter power must be turned on after the power supply for the logic and the interface signal is valid. The Backlight converter power must be turned off before the power supply for the logic and the interface signal is invalid.

Parameter	Value			Units
	Min	Typ	Max	
T1	0.5	---	10	ms
T2	0	---	50	ms
T3	0	---	50	ms
T4	500	---	---	ms
T5	450	---	---	ms
T6	200	---	---	ms
T7	10	---	100	ms
T8	10	---	---	ms
T9	10	---	---	ms
T10	20	---	50	ms

5.3 The Input Data Format

SEL68 = “Low” or “NC” for 6 bits LVDS Input

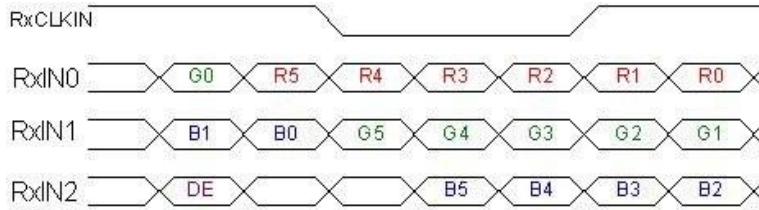

SEL68 = “High” for 8 bits LVDS Input

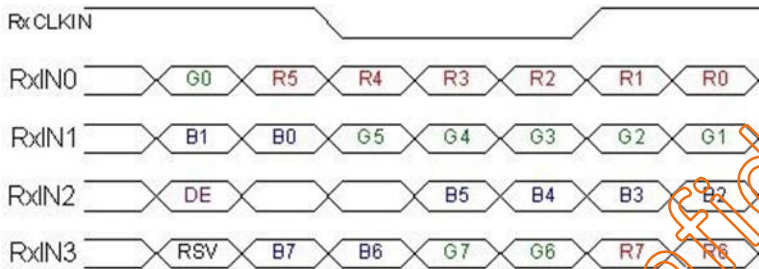

Note (1) R/G/B data 7: MSB, R/G/B data 0: LSB

Note (2) Please follow PSWG

Signal Name	Description	Remark
R7	Red Data 7 (MSB)	Red-pixel Data Each red pixel's brightness data consists of these 8 bits pixel data.
R6	Red Data 6	
R5	Red Data 5	
R4	Red Data 4	
R3	Red Data 3	
R2	Red Data 2	
R1	Red Data 1	
R0	Red Data 0 (LSB)	
G7	Green Data 7 (MSB)	Green-pixel Data Each green pixel's brightness data consists of these 8 bits pixel data.
G6	GreenData 6	
G5	GreenData 5	
G4	GreenData 4	
G3	GreenData 3	
G2	GreenData 2	
G1	GreenData 1	
G0	GreenData 0 (LSB)	
B7	Blue Data 7 (MSB)	Blue-pixel Data Each blue pixel's brightness data consists of these 8 bits pixel data.
B6	Blue Data 6	
B5	Blue Data 5	
B4	Blue Data 4	
B3	Blue Data 3	
B2	Blue Data 2	
B1	Blue Data 1	
B0	Blue Data 0 (LSB)	
RXCLKIN+	LVDS Clock Input	
RXCLKIN-		
DE	Display Enable	
VS	Vertical Sync	
HS	Horizontal Sync	

Note (3) Output signals from any system shall be low or Hi-Z state when VDD is off.

5.4 Scanning Direction

The following figures show the image see from the front view.

The arrow indicates the direction of scan

Fig.1 Normal Scan

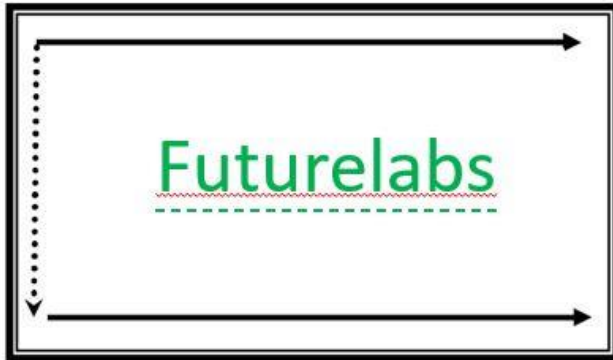

Fig.2 Reverse Scan

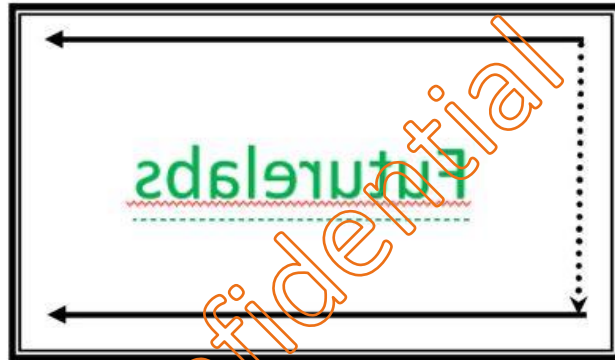

Fig.3 Reverse Scan



Fig.4 Reverse Scan



Fig. 1 Normal scan (pin 17, reLR=Low , pin 18, reUD= Low)

Fig. 2 Reverse scan (pin 17, reLR=High, pin 18, reUD= Low)

Fig. 3 Reverse scan (pin 17, reLR=Low , pin 18, reUD= High)

Fig. 4 Reverse scan (pin 17, reLR=High, pin 18, reUD= High)

6. INTERFACE PIN DESCRIPTION

6.1 LCM Connector PIN Assignment

Pin	Name	Description	Remark
1	RX3+	Differential Data Input, CH3 (Positive)	
2	RX3-	Differential Data Input, CH3 (Negative)	
3	NC	NC	
4	SEL68	LVDS 6/8 bit select function control, Low => 6 bit Input Mode High => 8bit Input Mode	Note (3) (4)
5	GND	Ground	
6	RXC+	Differential Clock Input (Positive)	
7	RXC-	Differential Clock Input (Negative)	
8	GND	Ground	
9	RX2+	Differential Data Input , CH2 (Positive)	
10	RX2-	Differential Data Input , CH2 (Negative)	
11	GND	Ground	
12	RX1+	Differential Data Input , CH1 (Positive)	
13	RX1-	Differential Data Input, CH1 (Negative)	
14	GND	Ground	
15	RX0+	Differential Data Input, CH0 (Positive)	
16	RX0-	Differential Data Input, CH0 (Negative)	
17	reLR	Horizontal Reverse Scan Control, Low => Normal Mode. High => Horizontal Reverse Scan	Note (3) (4)
18	reUD	Vertical Reverse Scan Control, Low => Normal Mode, High => Vertical Reverse Scan	Note (3) (4)
19	VCC	Power supply	
20	VCC	Power supply	

Note (1) Connector Part No.: STARCONN 076B20-0048RA-G4 or equivalent.

Note (2) User's connector Part No.: JAE FI-SE20ME or equivalent.

Note (3) "Low" stands for 0V. "High" stands for 3.3V.

Note (4) SEL68, reLR, reUD

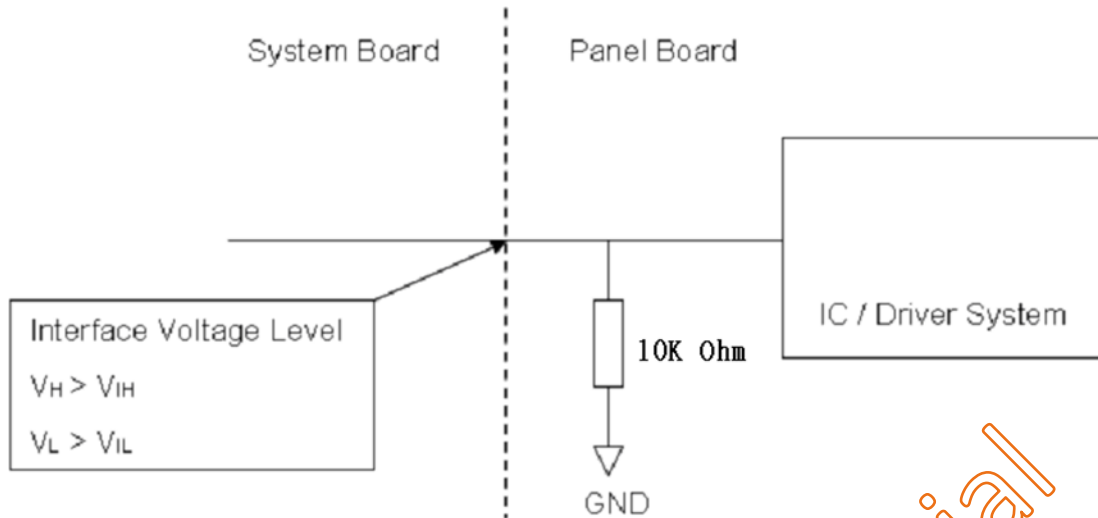

6.2 BACKLIGHT UNIT(Converter connector pin)

Pin	Symbol	Description	Remark
1	V_i	Converter input voltage	12V
2	V_i	Converter input voltage	12V
3	V_i	Converter input voltage	12V
4	V_i	Converter input voltage	12V
5	VGND	Converter ground	Ground
6	VGND	Converter ground	Ground
7	VGND	Converter ground	Ground
8	VGND	Converter ground	Ground
9	EN	Enable pin	3.3V, Note (3)
10	ADJ	Backlight Adjust	PWM Dimming (190-210Hz, Hi: 3.3V _{DC} , Lo: 0V _{DC}), Note (3)

Note (1) Connector Part No.: 91208-01001-H01 (ACES) or equivalent.

Note (2) User's connector Part No.: 91209-01011 (ACES) or equivalent

Note (3) EN(BLON), ADJ(E_PWM) as shown below :

BLON Pin

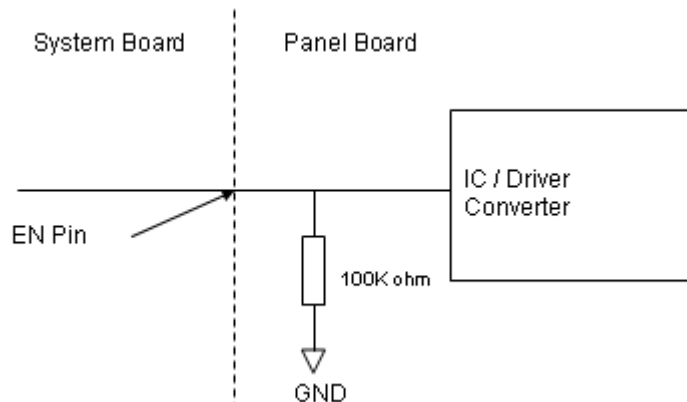

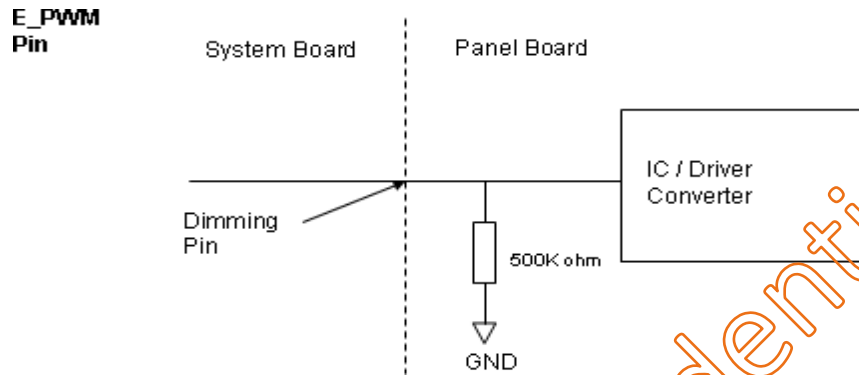

7. BLOCK DIAGRAM

The following diagram shows the functional block of the TFT module:

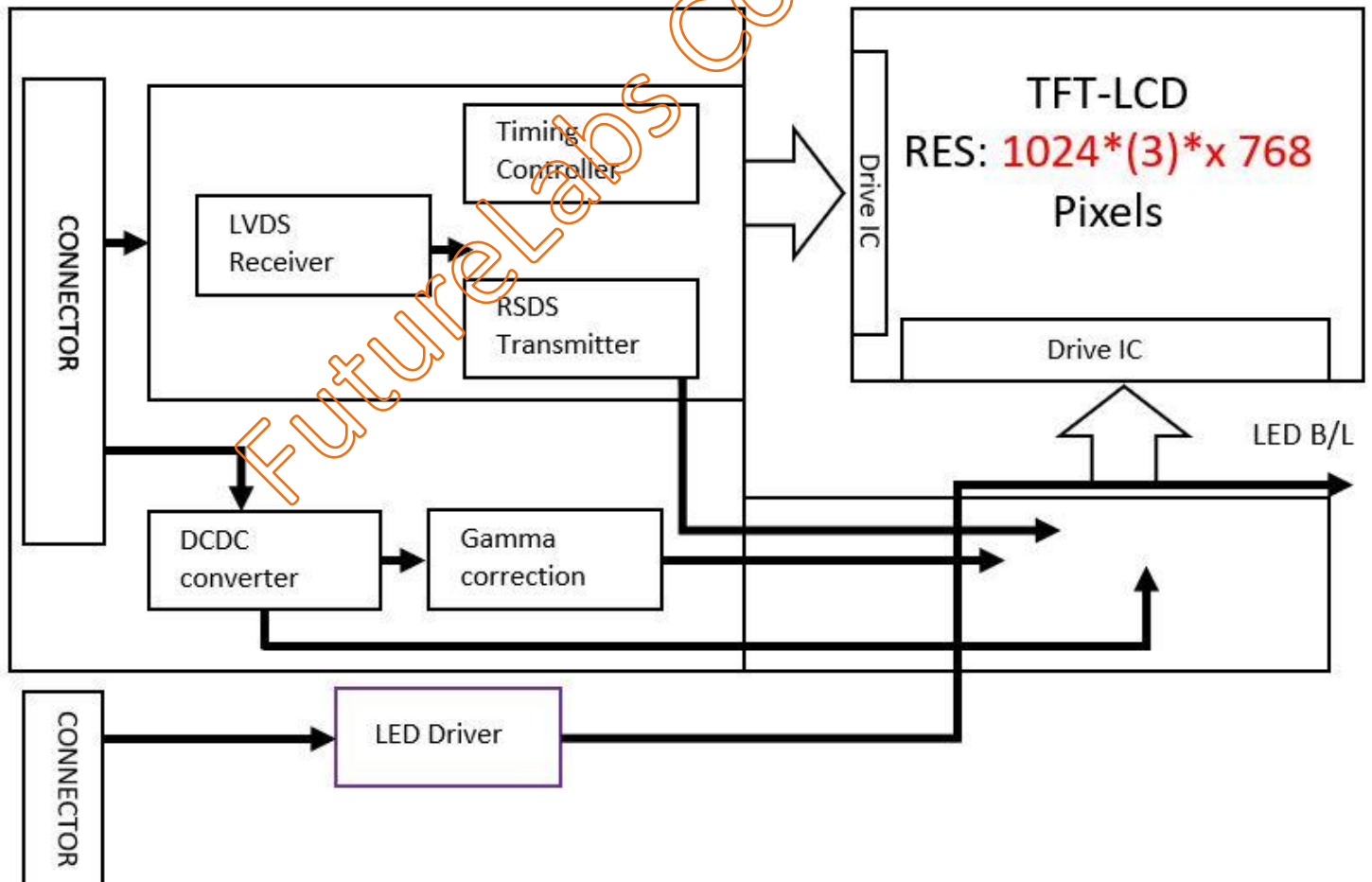

8. OPTICAL CHARACTERISTIC

The optical characteristics are measured under stable conditions at room temperature.

Item		Symbol	Condition	Min.	Typ.	Max.	Unit	Note
Contrast Ratio		CR	Viewing angle at normal direction $\theta_x=0^\circ, \theta_y=0^\circ$	700	1000		-	(2)(5)
Response Time		T _R		-	13	18	ms	(3)
		T _F		-	12	17	ms	
Center Luminance of White		LC		480	600	-	cd/m ²	(4)(5)
White Variation		δW		--	1.25	1.4	%	(5)(6)
Chromaticity	Red	R _x		Viewing angle at normal direction $\theta_x=0^\circ, \theta_y=0^\circ$	Typ. -0.05	0.652	Typ. +0.05	-
		R _y	0.338			-		
	Green	G _x	0.324			-		
		G _y	0.607			-		
	Blue	B _x	0.153			-		
		B _y	0.048			-		
	White	W _x	0.313			-		
		W _y	0.529			-		
Viewing Angle	Horizontal	θ_{x+}	CR=10	85	89	-	Deg.	(1)(5)
		θ_{x-}		85	89	-		
	Vertical	θ_{y+}		85	89	-		
		θ_{y-}		85	89	-		

The following optical specifications shall be measured in a darkroom or equivalent state (ambient luminance <2 lux, and at room temperature). The room temperature is 25°C±2°C.

Note 1: Definition of Viewing Angle

Viewing angle is the angle at which the contrast ratio is greater than 10. The viewing angles are determined for the horizontal or the vertical clock direction with respect to the optical axis which is normal to the LCD surface

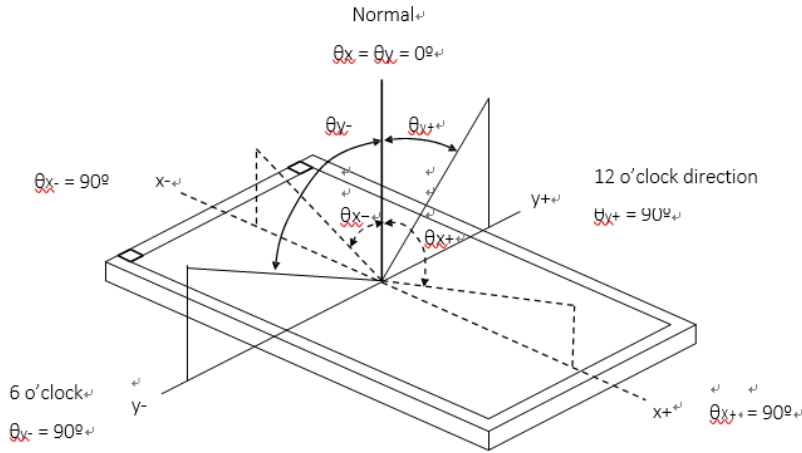

Note 2: Definition of Contrast Ratio (CR)

Measure the viewing angle of $\Theta = 0$ and at the center of the LCD surface. Luminance with all pixels in white state divide by Luminance with all pixels in Black state

Note 3: Definition of Response Time:

The response time is set initially by defining the "Rising Time (T_R)" and the "Falling Time (T_F)" respectively. Please refer the figure to the followings:

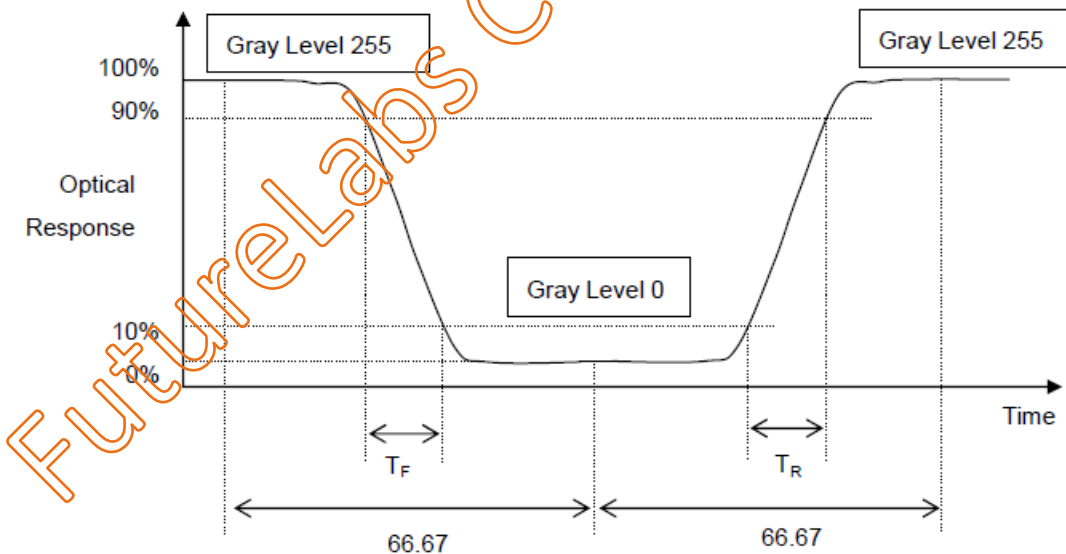

Note 4: Definition of Brightness (L)

Measure the center area of the panel and the viewing angle of the $\theta_x = \theta_y = 0^\circ$

Note 5: The method of optical measurement:

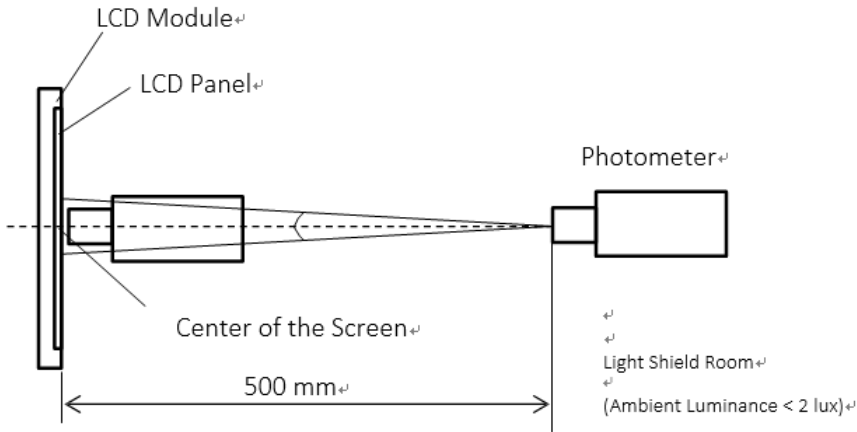

Note 6: Definition of White Variation (δW):

Measure the luminance of gray level 255 at 5 points

$$\delta W = \text{Maximum} [L(1), L(2), L(3), L(4) \sim L(9)] / \text{Minimum} [L(1), L(2), L(3), L(4) \sim L(9)]$$

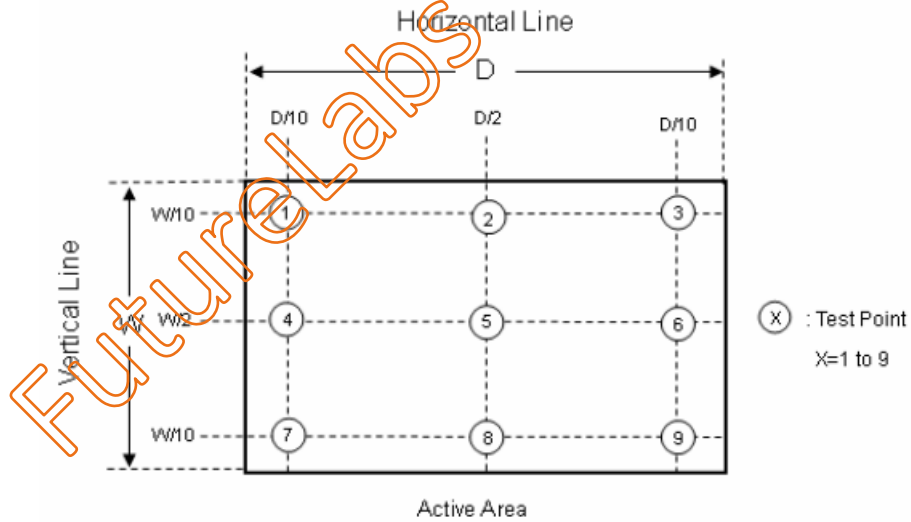

B. Touch Screen specification

1. Environmental Specification

Specification	Value	Remarks
Operating Temperature	-30°C ~ 80°C	
Storage Temperature	-40°C ~ 80°C	
Operating Humidity	20% ~ 90%RH	
Storage Humidity	10% ~ 90%RH	

2. Mechanical Specification

Specification	Value
Operating Life (Finger input)	10 ⁷ times
Light Transmittance	86% Min. (JIS K-7105) with glass
Surface hardness	Depending by the CoverLens Material Customer choose
FPC Peeling Force	5N Max

3. Combo Type Controller Combo USB-I2C

Parameters	Features
Circuit Board Dimension	Refer to drawings
Channels of Panel	Based on Sensor Design
Input Voltage	5V for USB - 5V/3.3V(Min 3.2V) for I2C
Linearity(Note 1)	Single Line drawing accuracy : Up to 1pt +/- 1mm offset /10mm
	Single Touch (point) accuracy : Up to 1pt +/- 1mm
Interface	USB: 2.0(Below) Full Speed I2C: 100K/400K Hz
Resolution	4096x4096 resolution
Power consumption(mA)	Active Mode: <108mA
	Idle Mode : <54mA
	Sleep Mode :< 10mA
	(Operation Mode: Active Mode only)
Report rate(points/sec) Note(2)	> 100 Hz
Response time	Average < 25 ms

Note (1): Depending by Sensor design and other parameters, Refer to Windows 8 Logo regulation if need to follow min spec



Note (2): Report rate will vary by channel number, cover thickness, number of fingers and other parameters

FutureLabs Confidential

9. DIMENSION AND DRAWING

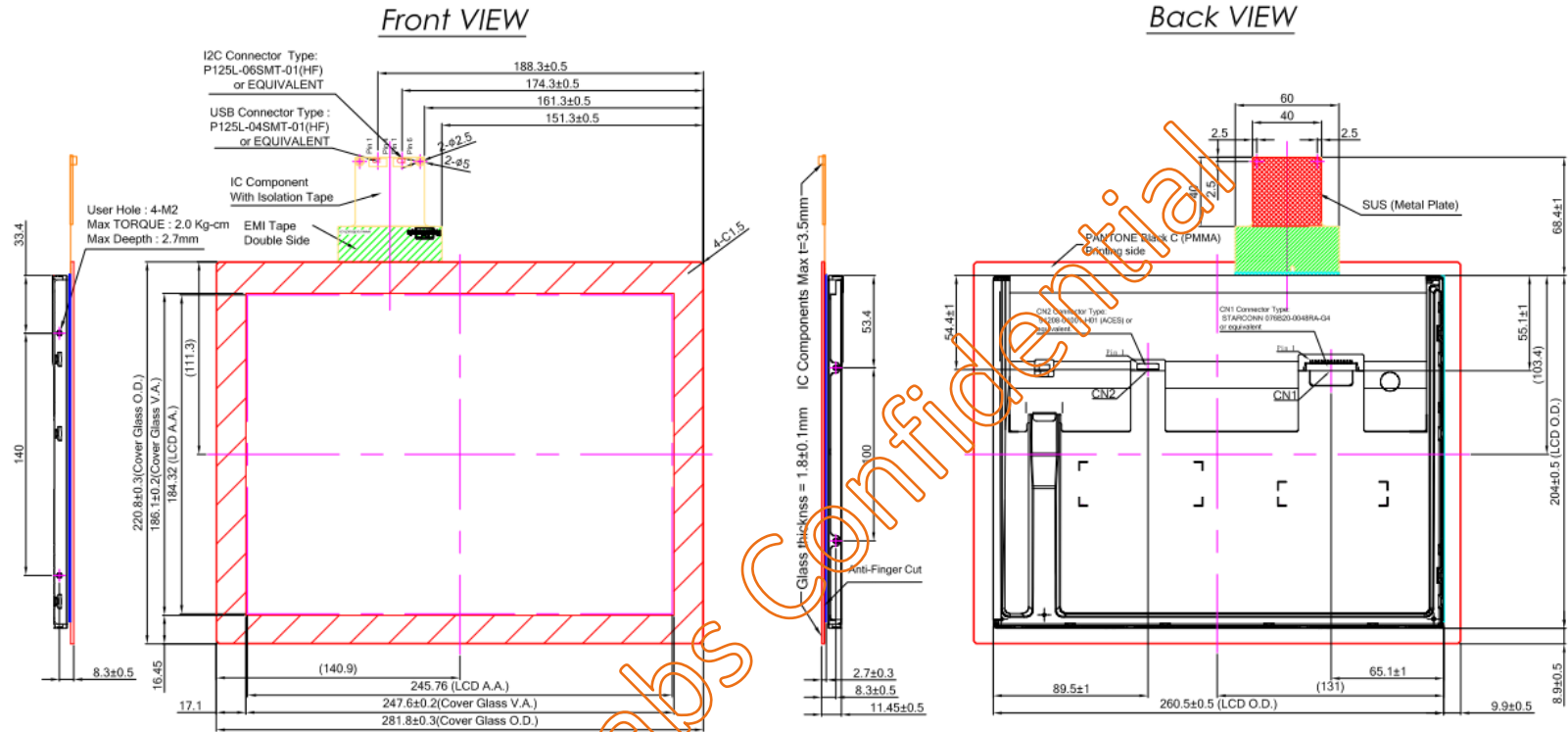

- Note:
1. Tolerance: ±0.3mm
 2. Touch Finger input only or special conductive pen
 3. Touch Surface Hardness: 6H (C.S. Glass)
 4. Touch Transmittance: >85% (JIS-K7105)
 5. Distance between LCD and touch panel need to be minimum 1.0mm otherwise touch maybe will not work correctly
 6. If customer put a front cover all around need use at least 2mm thick gasket between touch and metal frame
 7. Touch USB max ripple acceptable is 50mV, in other case touch will not work correctly
 8. Referring to the integration guide to avoid any integration noise issue
 9. LCD P/N : FLC-121GML2000SA1#00
 10. Touch P/N : RTPC121-0001-C#00
 11. Assembly Solution : DSA

C1: Pin Define for USB 4 pin		CN1 Pin Define				CN2 Pin Define	
PIN	SYMBOL	PIN	SYMBOL	PIN	SYMBOL	PIN	SYMBOL
Pin 01	GND	1	RX3+	11	GND	1	V _i
Pin 02	D-	2	RX3-	12	RX1+	2	V _i
Pin 03	D+	3	NC	13	RX1-	3	V _i
Pin 04	VDD (5V)	4	SEL68	14	GND	4	V _i
C2: Pin Define for I2C 6 pin		5	GND	15	RX0+	5	V GND
Pin 01	GND	6	RXC+	16	RX0-	6	V GND
Pin 02	SDA	7	RXC-	17	reLR	7	V GND
Pin 03	SCL	8	GND	18	reUD	8	V GND
Pin 04	VDDIOV3.3 (3.3VDC)	9	RX2+	19	VCC	9	EN
Pin 05	INT	10	RX2-	20	VCC	10	ADJ
Pin 06	RST						

Customer Approval		Part Number # REV		FLD-121GML20PCCA1		#00	
Date	Signature	Date	Signature	Date	Signature	Date	Signature
Company		Rev. No		Rev. No		Rev. No	
Name		001	20210320	001	20210320	001	20210320
		002	20210405	002	20210405	002	20210412
		003	20210412	003	20210412	003	20210412
Signature		004	20210412	004	20210412	004	20210412
		Date	Signature	Date	Signature	Date	Signature
		11/27/2021		11/27/2021		11/27/2021	

10. PRECAUTION AND PRODUCT HANDLING

- Do not apply the external force such as bending or twisting to the LCD panel and backlight during assembly.
- Do not insert and plug out the input connector while the LCD panel is operating.
- Do not take apart the panel or frame from LCD module assembly or insert anything into the backlight unit.
- Do not keep the same pattern in a long period of time, it may cause image sticking on LCD panel. Can use shuffle content periodically if fixed pattern is displayed on the screen.
- Do not touch the display area with bare hands, this will stain the display area.
- Pay attention to handle lead wire of backlight, that is not tugged in connect with LED driver.
- Do not change variable resistance settings in LCD panel, it may cause not satisfy of LCD characteristics specification.
- The surface of LCD panel's polarizer is very soft and easily scratched, please use a very soft dry cloth without chemicals for cleaning.
- To avoid the static electricity to damage the CMOS LSI, the operator should be grounded when in contact with the LCD panel, and also to all electrical equipment.
- Need to follow the correct power frequency when LCD panel is connecting and operating, this can avoid damage to CMOS LSI during latch-up.
- Need to store the LCD panel indoor without the exposure of sunlight where the temperature is $25^{\circ}\text{C} \pm 5^{\circ}\text{C}$ and the humidity is below 60% RH.