

## Product Specification

PART NUMBER # REV: FLD-133MML10PCSA1#00

DESCRIPTION: TFT 13.3"W 1920x1080 8bit LVDS 400CD Full View assembled

Rocktouch Pcap 1.8mm Black USB/I2C

( ) Preliminary Specification

( V ) Approved Specification

<b>Customer Name:</b>	
<b>Signature:</b>	<b>Date:</b>

PREPARED BY	REVIEWED BY	SIGNATURE DATE
<i>Ellen Chen</i>	<i>David</i>	<i>2021/01/11</i>

### Revision History

Version	Date	Page	Description	Note
V1.0	2021/01/11		First Edition	

FutureLabs Confidential

## Table of Content

Product Specification.....	1
<b>1. GENERAL DESCRIPTION.....</b>	<b>4</b>
1.1 Description.....	4
1.2 Product Summary .....	4
<b>2. ABSOLUTE MAXIMUM RATING.....</b>	<b>5</b>
2.1 Electrical Absolute Rating .....	5
2.2 Environment Absolute Rating .....	5
<b>3. ELECTRICAL CHARACTERISTICS.....</b>	<b>6</b>
3.1 LCD Electrical Specification .....	6
3.2 Signal Electrical Characteristics .....	7
3.3 Backlight Unit .....	7
<b>4. Interface Timing .....</b>	<b>8</b>
4.1 Timing.....	8
4.2 Timing Diagram .....	9
4.3 Power On/Off Sequence .....	9
<b>5. INTERFACE PIN DESCRIPTION .....</b>	<b>11</b>
5.1 LCM Connector PIN Assignment.....	11
5.2 Backlight PIN Assignment .....	12
<b>7. BLOCK DIAGRAM .....</b>	<b>14</b>
<b>8. OPTICAL CHARACTERISTIC.....</b>	<b>15</b>
<b>9. DIMENSION AND DRAWING.....</b>	<b>18</b>
<b>10. PRECAUTION AND PRODUCT HANDLING .....</b>	<b>Errore. Il segnalibro non è definito.</b>
<b>11. Touch Screen specification.....</b>	<b>19</b>
11.1 Environmental Specification.....	19
11.2 Mechanical Specification .....	19
11.3 Combo Type Controller .....	19
<b>12. PRECAUTION AND PRODUCT HANDLING .....</b>	<b>20</b>

# 1. GENERAL DESCRIPTION

## 1.1 Description

13.3"W is a Color Active Matrix Liquid Crystal Display Module composed of a TFT LCD panel and LED backlight system. The screen format is intended to support the 1920x1080 screen and 16.7 M colors.

## 1.2 Product Summary

The following items are summary on the table under Ta=25 °C condition:

No.	Item	Specification	Unit
1	Display Size	13.3"W	Inch
2	Pixel Number	1920 (H) x 3(RGB)x 1080 (V)	Pixels
3	Outline Dimension	324.16(W)x204.64(H)x13.75(D)	mm
4	Active Area	293.472 (H) x 165.078 (V)	mm
5	Pixel Pitch	152.85x152.85	um
6	Display Colors	16.7M colors	
7	Pixel Arrangement	RGB vertical stripe	--
8	Display Mode	Full View / Normally Black	--
9	Electrical Interface	LVDS	--
10	Surface Treatment	Antiglare	--
11	Brightness	400 (Typ.)	cd/m2
12	Contrast Ratio	800:1 (Typ.)	--

## 2. ABSOLUTE MAXIMUM RATING

### 2.1 Electrical Absolute Rating

Item	Symbol	Values			Unit	Note
		Min	Typ	Max		
Logic/LCD Drive Voltage	VDD	-0.3	-	4.0	V	Note (1), (2)
Signal Voltage	RinI-/+, CLKIN-/+	-0.3	-	VDD+0.3	V	Note (1), (2)
Signal Voltage	LED EN, LED PWM	-0.3	-	5.5	V	Note (1), (2)

Note (1) Permanent damage to the device may occur if max values are exceeded.

Function operation should be restricted to the conditions described under normal operating conditions.

(2) Specified values are for input pin of LED light bar at  $T_a = 25 \pm 2^\circ\text{C}$

### 2.2 Environment Absolute Rating

Item	Symbol	Values			Unit	Note
		Min	Typ	Max.		
Operating Temperature	Top	-20		70	$^\circ\text{C}$	Note(1)(2)
Storage Temperature	Tstg	-20		70	$^\circ\text{C}$	

Note (1): The absolute maximum rating values of this product are not allowed to be exceeded at any times. The module should not be used over the absolute maximum rating value. It will cause permanently unrecoverable function fail in such a condition

### 3. ELECTRICAL CHARACTERISTICS

#### 3.1 LCD Electrical Specification

Item	Symbol	Min.	Type	Max.	Unit.	Note
LCD logic Driver voltage	VDD	3.0	3.3	3.6	V	
Inrush current	IRush	-	-	2	A	Note 2
LCD Input current	IDD	-	-	500	mA	Note 1
VDD power consumption	PDD	-	-	1.8	W	Note 1
Allowable logic/LCD driver ripple voltage	VDDrp	-	-	200	mV p-p	

Note 1: Maximum measurement condition: white patter at 3.6V driving voltage

Note 2: Measure condition

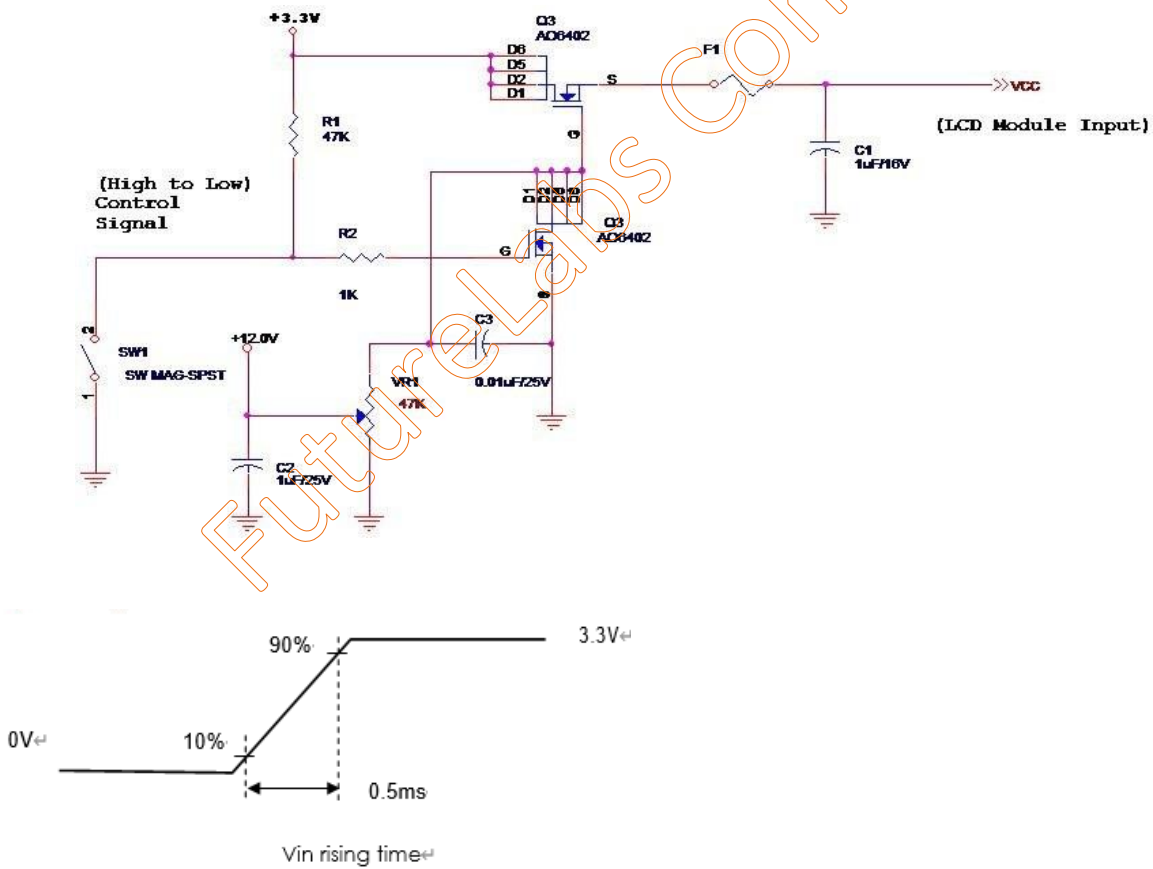

### 3.2 Signal Electrical Characteristics

Item	Symbol	Min.	Typ.	Max.	Unit	Note
Differential Input High Threshold	VTH	-	-	+100	mV	VCM=1.2V
Differential Input Low Threshold	VTL	-100	-	-	mV	VCM=1.2V
Input Differential Voltage	VID	100	400	600	mV	
Differential Input Common Mode Voltage	VCM	+1.125	-	+1.375	V	VTH-VTL=200MV(max)

### 3.3 Backlight Unit

Parameter guideline for LED driving is under stable conditions at 25°C (Room Temperature):

Item	Symbol	Min.	Typ.	Max.	Unit	Note
Power voltage	VLED	10.8	12	13.2	V	
LED Input current	ILED	-	1.25	-	A	
LED Enable Input High Level	LED_EN	2	-	5	V	
LED Enable Input Low Level		-	-	0.8	V	
PWM Logic Input High Level	LED_PWM	2	-	5	V	
PWM Logic Input Low Level		-	-	0.52	V	
PWM Input Frequency	FPWM	500	-	10K	Hz	
PWM Duty Ratio	Duty	5	-	100	%	
LED Inrush Current	ILED <sub>Rush</sub>	-	-	3	A	
BL Power Consumption	PLED	-	-	15	W	
Operating LED life time	Hr	-	50,000	-	Hour	

Note: (1) Permanent damage may occur to the LCD module if beyond this specification. Functional operation should be restricted to the conditions described under normal operating conditions.

(2) The “LED life time” is defined as the module brightness decrease to 50% original brightness at Ta=25°C

## 4. Interface Timing

### 4.1 Timing

Signal	Item	Symbol	Min	Typ	Max	Unit
Clock	Frequency	1/ TClock	67	70.6	74.5	MHz
Frame Rate			-	60	-	Hz
Vertical section	Period	TV	1092	1116	1080+A	T-line
	Active	TVD	1080	1080	1080	
	Blanking	TVB	12	36	A	
Horizontal Section	Period	TH	1023	1054	960+B	T-clock
	Active	THD	960	960	960	
	Blanking	THB	63	94	B	

Note1 : The above is as optimized setting

Note2 : The maximum clock frequency =  $[(960 + B) * (1080 + A) * 60] < 74.5\text{MHz}$

Note3 : Horizontal related parameters must be constant without variation( H\_Sync\_Width,

H\_Front\_Porch and H\_Back\_Porch must be constant on each scanline).

Note4 : On vertical blank area, H\_Sync\_Width and H\_Total must be same as on the V\_Active area.

Note5 : Vertical related parameters must be constant without variation.( V\_Sync\_Width,

V\_Front\_Porch and V\_Back\_Porch must be constant on each video field ).

Note6 : The DE timings also must be constant without variation( H/V timing requirements are as same as previous. Blank timing must also be constant ).



## 4.2 Timing Diagram

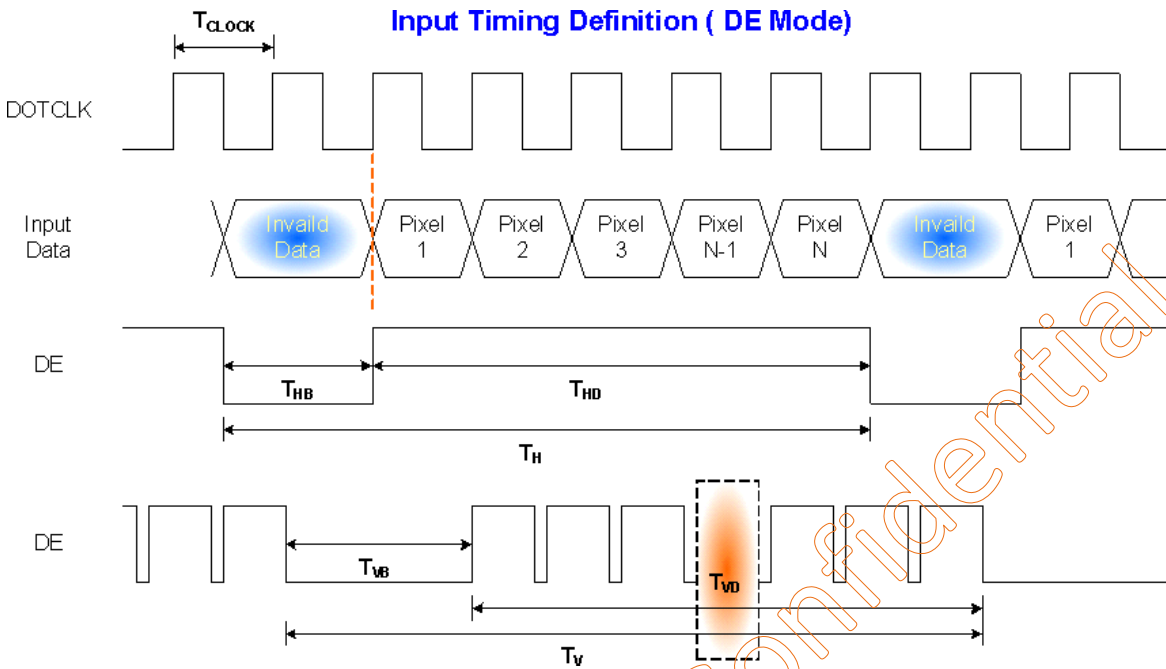

## 4.3 Power On/Off Sequence

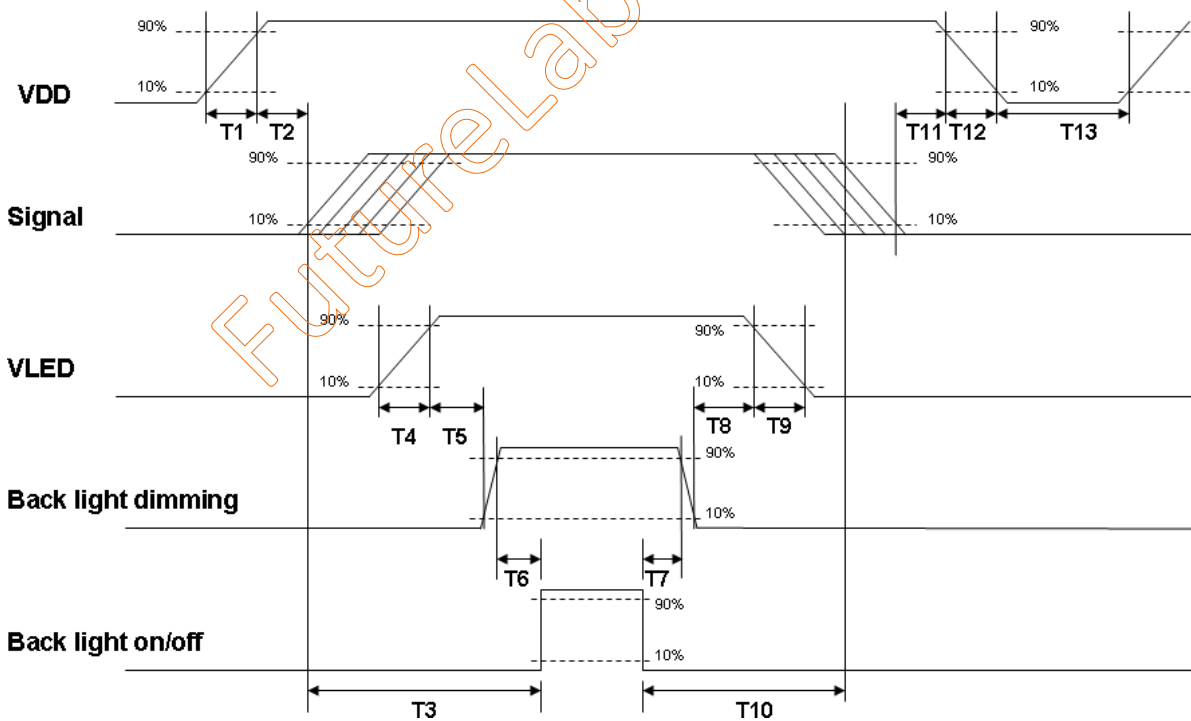

Parameter	Value			Units
	Min.	Typ.	Max.	
T1	0.1	-	10	[ms]
T2	200	-	-	[ms]
T3	50	-	-	[ms]
T4	0.5	-	10	[ms]
T5	10	-	-	[ms]
T6	10	-	-	[ms]
T7	10	-	-	[ms]
T8	10	-	-	[ms]
T9	0.5	-	10	[ms]
T10	50	-	-	[ms]
T11	10	-	-	[ms]
T12	-	-	10	[ms]
T13	1000	-	-	[ms]

FutureLabs Confidential

## 5. INTERFACE PIN DESCRIPTION

### 5.1 LCM Connector PIN Assignment

CN1 connector is DF19K-30P-1H(54) or Equivalent and mating housing part number is DF19G-30S-1C(05) or DF19A-2830SCFA(41) or equivalent

Pin No.	Symbol	Function
1	RXinO0-	- LVDS differential data input (Odd data)
2	RXinO0+	+ LVDS differential data input (Odd data)
3	RXinO1-	- LVDS differential data input (Odd data)
4	RXinO1+	- LVDS differential data input (Odd data)
5	RXinO2-	+LVDS differential data input (Odd data)
6	RXinO2+	-LVDS differential data input (Odd data)
7	GND	Power Ground
8	RXOCLKIN-	-LVDS differential clock input (Odd clock)
9	RXOCLKIN+	+LVDS differential clock input (Odd clock)
10	RXinO3-	+LVDS differential data input (Odd data)
11	RXinO3+	-LVDS differential data input (Odd data)
12	RXinE0-	- LVDS differential data input (Even data)
13	RXinE0+	+ LVDS differential data input (Even data)
14	GND	Power Ground
15	RXinE1-	- LVDS differential data input (Even data)
16	RXinE1+	+ LVDS differential data input (Even data)
17	GND	Power Ground
18	RXinE2-	- LVDS differential data input (Even data)
19	RXinE2+	+ LVDS differential data input (Even data)
20	RXECLKIN-	-LVDS differential clock input (Even clock)

21	RXECLKIN+	+LVDS differential clock input (Even clock)
22	RXinE3-	- LVDS differential data input (Even data)
23	RXinE3+	+ LVDS differential data input (Even data)
24	GND	Power Ground
25	NC	No Connection
26	VDD	Power +3.3V
27	VDD	Power +3.3V
28	NC	No Connection
29	NC	No Connection
30	GND	Power Ground

## 5.2 Backlight PIN Assignment

CN2 model is DF19G-8P-1H(54) and mating housing part number is DF19G-8S-1C(05) or DF19A-2830SCFA (41) or equivalent

PIN #	SIGNAL NAME	DESCRIPTION
1	LED_EN	LED enable pin
2	LED_PWM	System PWM Single Input
3	NC	No connect
4	VLED	+12V
5	VLED	+12V
6	NC	No connect
7	GND	Ground
8	GND	Ground

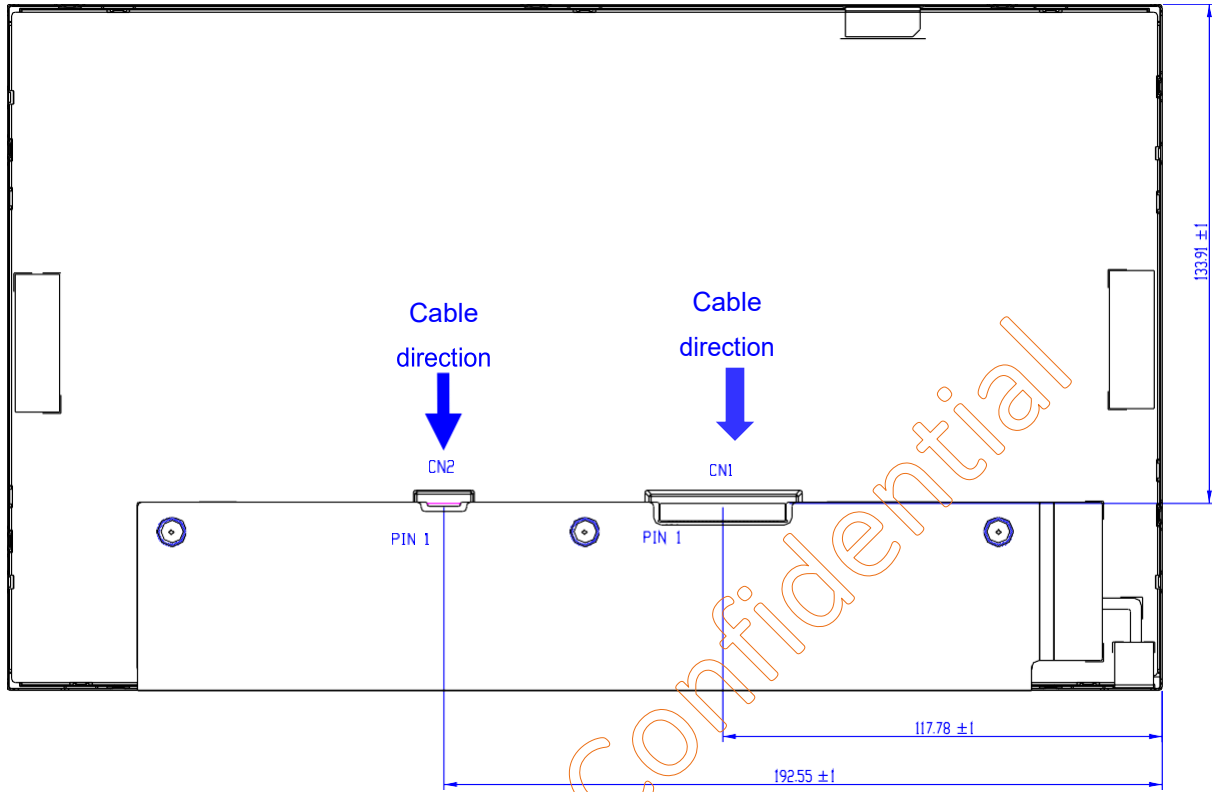

## 6. BLOCK DIAGRAM

The following diagram shows the functional block of the TFT module:

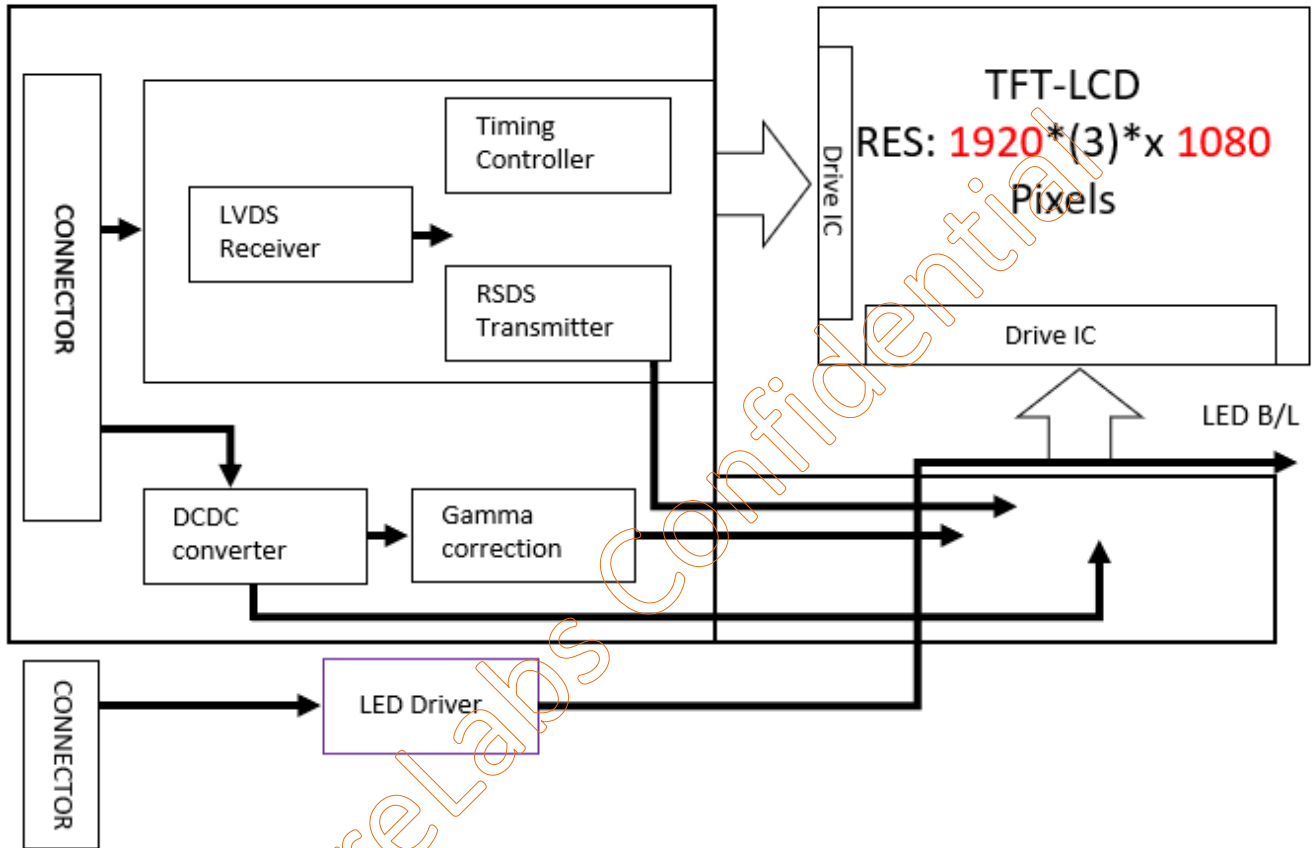

## 7. OPTICAL CHARACTERISTIC

The optical characteristics are measured under stable conditions at room temperature.

Item		Symbol	Condition	Min.	Typ.	Max.	Unit	Note	
Contrast Ratio		CR		600	800		-	(2)(5)	
Response Time		TR+TF		-	25	35	ms	(3)	
Center Luminance of White		LC		320	400	-	cd/m <sup>2</sup>	(4)(5)	
Brightness uniformity				75	80	-	%	(5)(6)	
Chromaticity	Red	R <sub>x</sub>	$\theta_x=0^\circ, \theta_y=0^\circ$ Viewing angle at normal direction	Typ.	0.675	Typ.	-	(1) (5)	
		R <sub>y</sub>			0.316		-		
	Green	G <sub>x</sub>			0.285		-		
		G <sub>y</sub>			0.655		-		
	Blue	B <sub>x</sub>			-0.05		0.153		-
		B <sub>y</sub>			0.036		+0.05		-
	White	W <sub>x</sub>			0.313		-		
		W <sub>y</sub>			0.329		-		
Viewing Angle	Horizontal	$\theta_{x+}$	CR=10	75	89	-	Deg.	(1)(5)	
		$\theta_{x-}$		75	89	-			
	Vertical	$\theta_{y+}$		75	89	-			
		$\theta_{y-}$		75	89	-			
NTSC				90			%		

The following optical specifications shall be measured in a darkroom or equivalent state (ambient luminance <2 lux, and at room temperature).

The room temperature is 25°C±2°C.

Note 1: Definition of Viewing Angle

Viewing angle is the angle at which the contrast ratio is greater than 10. The viewing angles are determined for the horizontal or the vertical clock direction with respect to the optical axis which is normal to the LCD surface

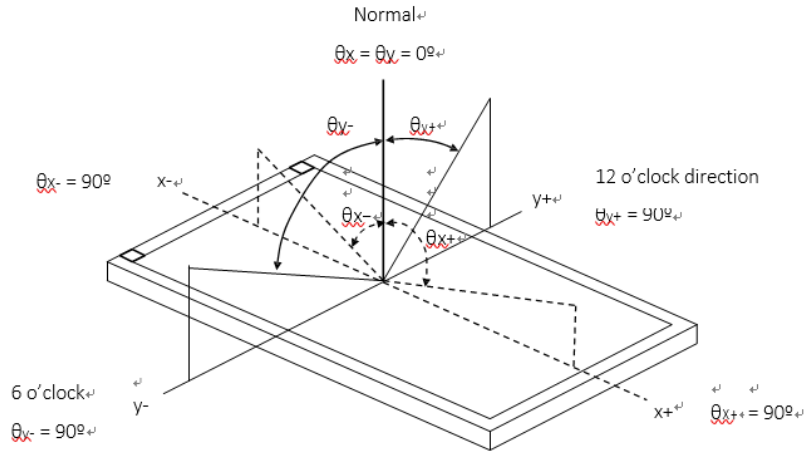

Note 2: Definition of Contrast Ratio (CR)

Measure the viewing angle of  $\Theta = 0$  and at the center of the LCD surface. Luminance with all pixels in white state divide by Luminance with all pixels in Black state

Note 3 Definition of Response Time:

The response time is set initially by defining the "Rising Time ( $T_R$ )" and the "Falling Time ( $T_F$ )" respectively. Please refer the figure to the followings:

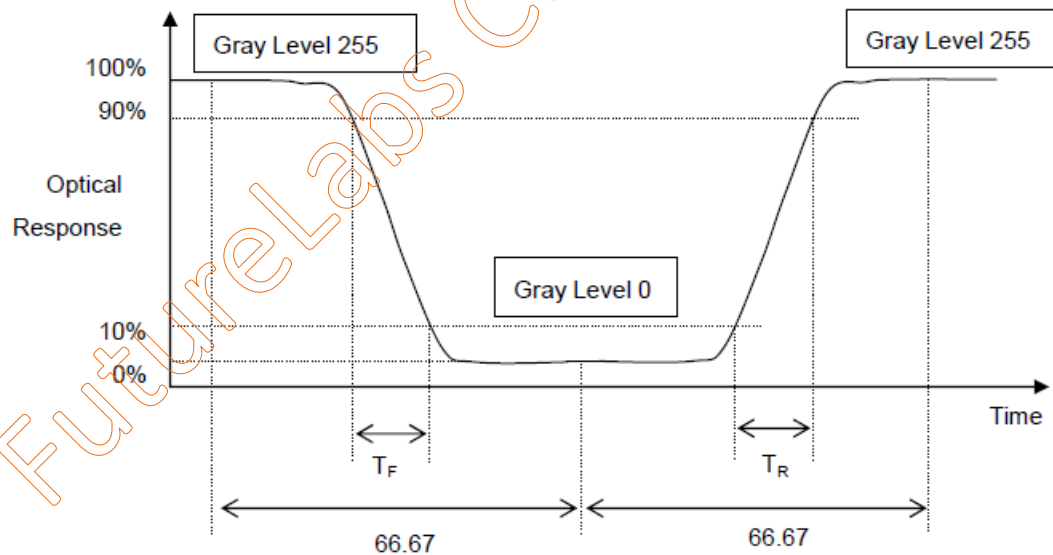

Note 4: Definition of Brightness (L)

Measure the center area of the panel and the viewing angle of the  $\theta_x = \theta_y = 0^\circ$

Note 5: The method of optical measurement:



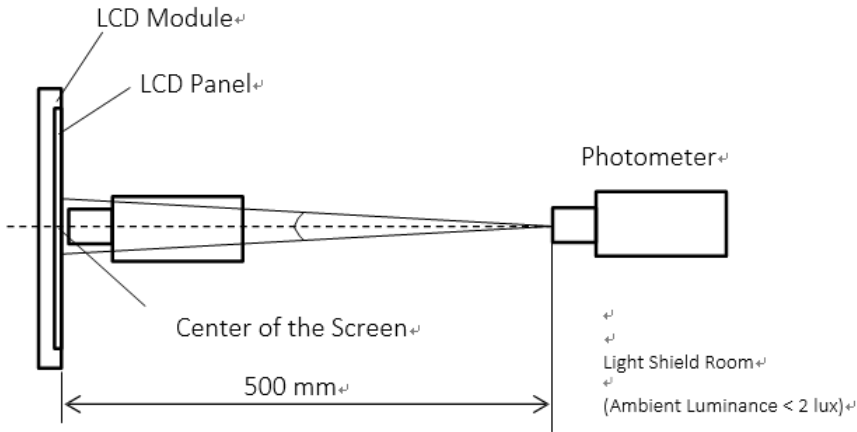

Note 6: Definition of White Variation ( $\delta W$ ):

Measure the luminance of gray level 255 at 5 points

$$\delta W = \text{Maximum} [L (1), L (2), L (3), L (4), L (5)] / \text{Minimum} [L (1), L (2), L (3), L (4), L (5)]$$

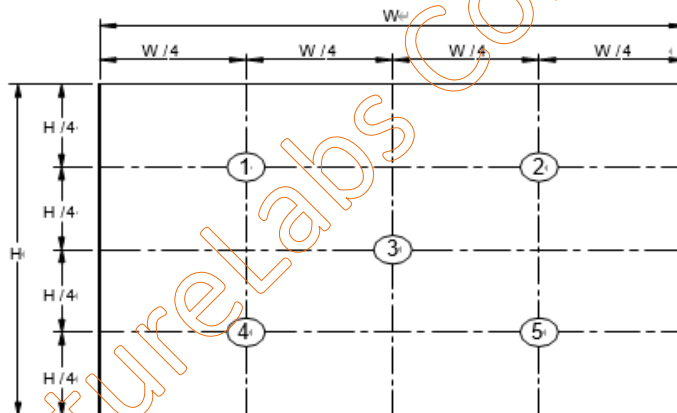

# 8. DIMENSION AND DRAWING

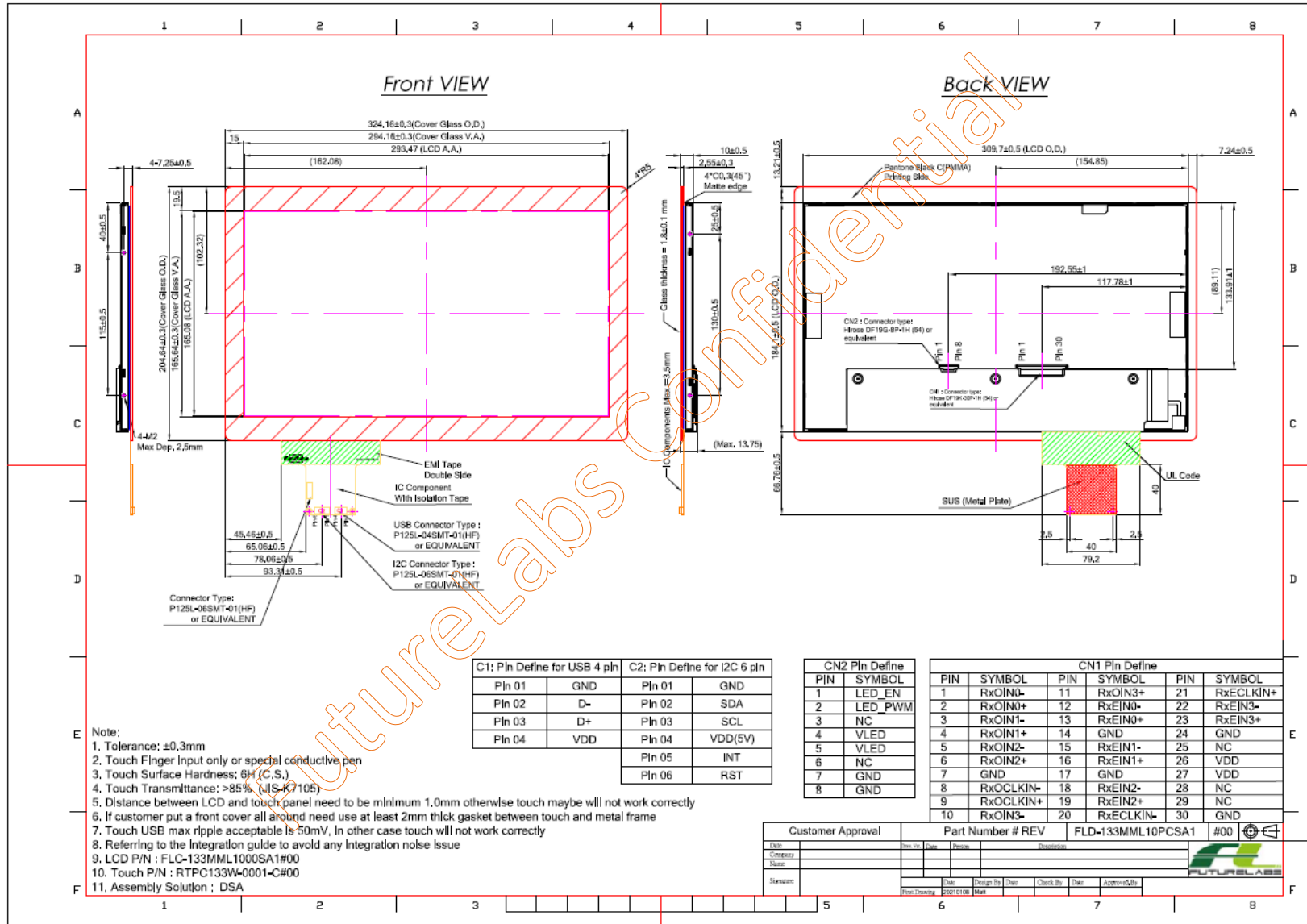

## 9. Touch Screen specification

### 9.1 Environmental Specification

Specification	Value
Operating Temperature	-20°C ~ 70°C
Storage Temperature	-30°C ~ 80°C
Operating Humidity	20% ~ 90%RH
Storage Humidity	10% ~ 90%RH

### 9.2 Mechanical Specification

Specification	Value
Operating Life (Finger input)	10 <sup>7</sup> times
Light Transmittance	>85% Min. (JIS K-7105) with glass
Surface hardness	6H
FPC Peeling Force	5N Max

### 9.3 Combo Type Controller

Parameters	Features
Circuit Board Dimension	Refer to drawings
Channels of Panel	Based on Sensor Design
Input Voltage	3.5V~5.5V Typical 5V for USB suggest to use 5V for I2C too
Linearity(Note 1)	Single Line drawing accuracy : Up to 1pt +/- 1mm offset /10mm
	Single Touch (point) accuracy : Up to 1pt +/- 1mm
Interface	USB: 2.0(Below) Full Speed I2C:100K/400K Hz
Resolution	4096×4096 resolution
Power consumption(mA)	Active Mode: <50mA
	Idle Mode : <45mA
	Sleep Mode :<15mA
	(Operation Mode :Active Mode only)
Report rate(points/sec) Note(2)	> 100 Hz
Response time	Average < 25 ms

Note (1): Depending by Sensor design and other parameters, Refer to Windows 8 Logo regulation if need to follow min spec

Note (2): Report rate will vary by channel number, cover thickness, number of fingers and other parameter

## 10. PRECAUTION AND PRODUCT HANDLING

- Do not apply the external force such as bending or twisting to the LCD panel and backlight during assembly.
- Do not insert and plug out the input connector while the LCD panel is operating.
- Do not take apart the panel or frame from LCD module assembly or insert anything into the backlight unit.
- Do not keep the same pattern in a long period of time, it may cause image sticking on LCD panel. Can use shuffle content periodically if fixed pattern is displayed on the screen.
- Do not touch the display area with bare hands, this will stain the display area.
- Pay attention to handle lead wire of backlight, that is not tugged in connect with LED driver.
- Do not change variable resistance settings in LCD panel, it may cause not satisfy of LCD characteristics specification.
- The surface of LCD panel's polarizer is very soft and easily scratched, please use a very soft dry cloth without chemicals for cleaning.
- To avoid the static electricity to damage the CMOS LSI, the operator should be grounded when in contact with the LCD panel, and also to all electrical equipment.
- Need to follow the correct power frequency when LCD panel is connecting and operating, this can avoid damage to CMOS LSI during latch-up.
- Need to store the LCD panel indoor without the exposure of sunlight where the temperature is  $25^{\circ}\text{C} \pm 5^{\circ}\text{C}$  and the humidity is below 60% RH.