

TFT Product Specification

- ◇ PRELIMINARY SPECIFICATION
- ◆ APPROVED SPECIFICATION

Part Number: FLD-121HML20PCSA2

Description: 12.1" w TFT LCD 600CD with LVDS interface, 1280x800
format display 262K/16.7M colors assemble Pcap 3.0mm Black
COMBO USB /I2C

Prepared by: Natalie

Confidential

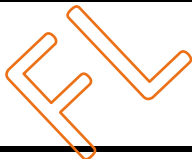
 Approved by	
Date	

Revision History

Version	Date	Page	Description	Note
V0.1	2020/03/17		First Edition	
V1.1	2020/09/08		Update code into spec	
V1.2	2022/03/01		Update Backlight life time	

Confidential



Table of Content

TFT Product Specification.....	1
1. GENERAL DESCRIPTION	4
1.1 Description	4
1.2 Product Summary	4
2. ABSOLUTE MAXIMUM RATING.....	5
2.1 Electrical Absolute Rating	5
2.2 Environment Absolute Rating.....	5
3. ELECTRICAL CHARACTERISTICS	6
3.1 LCM.....	6
3.2 Backlight Unit.....	8
4. SIGNAL CHARACTERISTICS.....	9
4.1 Interface Timing	9
4.1.1 Timing Characteristics.....	9
4.1.2 COLOR DATA INPUT ASSIGNMENT	11
4.2 Power ON/OFF Sequence	13
4.3 The Input Data Format	14
5. INTERFACE PIN DESCRIPTION	16
5.1 LCM Connector PIN Assignment.....	16
6. BLOCK DIAGRAM.....	18
7. OPTICAL CHARACTERISTIC.....	19
B. Touch Screen specification.....	22
1. Environmental Specification.....	22
2. Mechanical Specification	22
3. COMBO Type Controller	22
9. DIMENSION AND DRAWING.....	24
10. PRECAUTION AND PRODUCT HANDLING	25

1. GENERAL DESCRIPTION

1.1 Description

12.1" is a Color Active Matrix Liquid Crystal Display Module composed of a TFT LCD panel and LED backlight system. The screen format is intended to support the Wide-XGA, 1280x800 screen and 262K/16.7M colors.

1.2 Product Summary

The following items are summary on the table under Ta=25 °C condition:

No.	Item	Specification	Unit
1	Display Size	12.1w	Inch
2	Pixel Number	1280 (H) × RGB × 800 (V)	Pixels
3	Outline Dimension	328 (H) × 226 (V) × 14.5 (D)	mm
4	Active Area	261.12 (H) × 163.2 (V)	mm
5	Display Colors	262K/16.7M	--
6	Pixel Arrangement	RGB vertical stripe	--
7	Display Mode	Normally Black	--
8	Electrical Interface	LVDS	--
9	Surface Treatment	Anti-Glare, 3H hard coating	--
10	Brightness	600 (Typ.)	cd/m ²
11	Contrast Ratio	1000 (Typ.)	--
12	Total Power Consumption (Typ)	11.05(white pattern)	W

2. ABSOLUTE MAXIMUM RATING

2.1 Electrical Absolute Rating

Item	Symbol	Values			Unit	Note
		Min	Typ	Max.		
Power supply voltage	VCC	-0.3	--	4.0	V	(1)
Converter Voltage	Vin	-0.3	--	Vcc+0.3	V	(1)
LED Converter Input voltage		10.8	12.0	13.2	VDC	(1)(2)
LED Converter Input current		-	(0.8)	-	ADC	(1)(2)

Note (1) Permanent damage to the device may occur if maximum values are exceeded.

Function operation should be restricted to the conditions described under Normal Operating Conditions.

Note (2) Specified values are for LED

2.2 Environment Absolute Rating

Item	Symbol	Values			Unit	Note
		Min	Typ	Max.		
Operating Temperature	Top	-30		80	°C	(1)(2)
Storage Temperature	Tstg	-30		85	°C	

Note (1) 90%RH Max. (Ta<40°C)

Note (2) Wet-bulb temperature should be 39°C Max.

3. ELECTRICAL CHARACTERISTICS

3.1 LCM

Parameter	Symbol	Value			Unit	Note
		Min.	Typ.	Max.		
Power Supply Voltage	V _{CC}	3.0	3.3	3.6	V	
Permissive Ripple Voltage	V _{RP}	-	50	-	mV	
Rush Current	I _{RUSH}	1.5			A	(2)
Initial Stage Current	I _{IS}	-	-	1.0	A	(2)
Power Supply Current	White	400	440	480	mA	(3)b
	Black	260	290	320	mA	
LVDS Differential Input High Threshold	V _{TH(LVDS)}	+100	-	-	mV	-
LVDS Differential Input Low Threshold	V _{TL(LVDS)}	-	-	-100	v	-
LVDS Common Mode Voltage	V _{CM}	(1.125)	-	(1.375)	V	
LVDS Differential Input Voltage	I _{VIDI}	100	-	600	mV	
Terminating Resistor	R _T	-	100	-	Ohm	

Note (1) The assembly should be always operated within above ranges.

Note (2) Measurement Conditions:

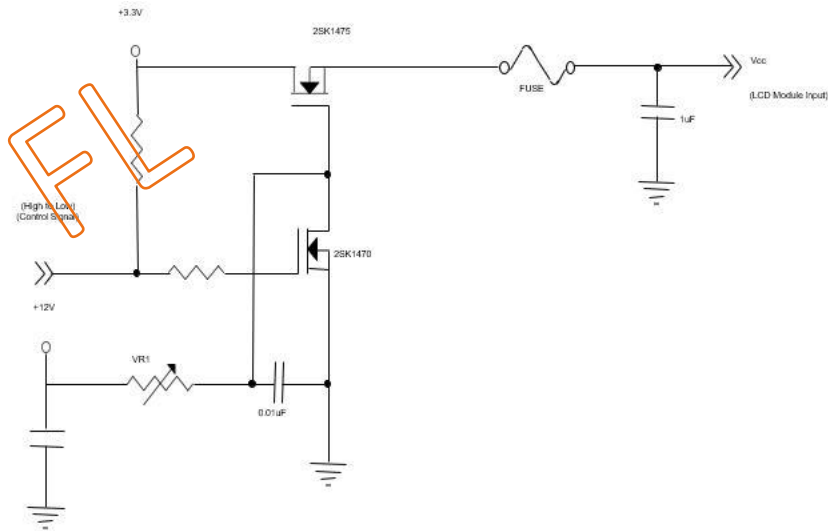

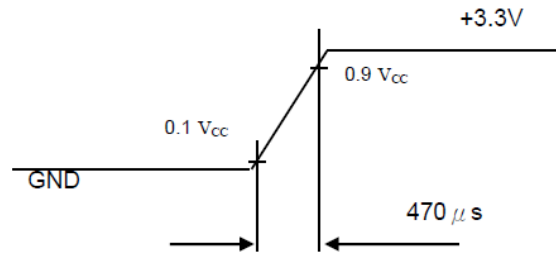

Note (3) The specified power supply current is under the conditions at $V_{CC} = 3.3 V$, $T_a = 25 \pm 2 \text{ }^\circ C$, $f_v = 60 \text{ Hz}$, whereas a power dissipation check pattern below is

a. White Pattern



Active Area

b. Black Pattern

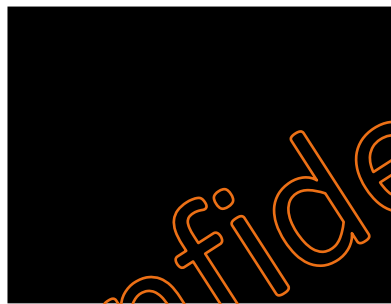

Active Area

c. Vertical Stripe Pattern

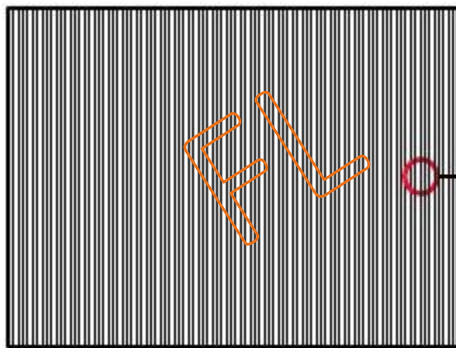

Active Area

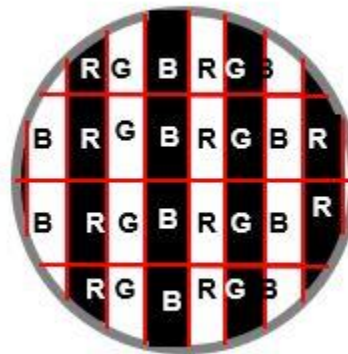

Confidential

3.2 Backlight Unit

Parameter guideline for LED driving is under stable conditions at 25°C (Room Temperature):

Parameter	Symbol	Min.	Typ.	Max.	Unit	Note	
Converter input Voltage	V_i	10.8	12.0	13.2	V _{DC}	(Duty 100%)	
Converter input ripple Current	V_{iRP}	--	--	350	mV		
Converter input Current	I_i	--	0.8	1.0	A _{DC}	@ $V_i=12V$ (Duty 100%)	
Converter inrush current	I_{iRUSH}			3.0	A	@ V_i rising time = 10ms($V_i=12V$)	
LED Power consumption	P_i		9.6		W	(1)	
EN Control Level	Backlight on	ENLED (BLON)	2.5	3.3	5.0	V	
	Backlight off		0	--	0.3	V	
PWM Dimming Control Level	PWM High Level	Dimming (E_PWM)	2.5	--	5.0	V	
	PWM Low Level		0	--	0.15	V	
PWM Dimming Control Frequency	f_{PWM}	190	200	20K	Hz	(3)	
PWM Dimming Control Duty Ratio			5		100	%	(3) Suggestion@ $190Hz \leq f_{PWM} < 1kHz$
			20		100	%	(3) Suggestion@ $1kHz \leq f_{PWM} \leq 20kHz$
PWM Noise Range	V_{Noise}			0.1	V		
LED life Time (Typical)	LBL	50,000	70000	--	Hrs	(2)	

Note (1) LED current is measured by utilizing a high frequency current meter as shown below:

Note (2) The lifetime of LED is estimated data and defined as the time when it continues to operate under the conditions at $T_a = 25 \pm 2$ °C and Duty 100% until the brightness becomes $\leq 50\%$ of its original value.

Operating LED at high temperature condition will reduce life time and lead to color shift.

Note (3) At 190 ~1kHz PWM control frequency, duty ratio range is restricted from 5% to 100%.

1K ~20kHz PWM control frequency, duty ratio range is restricted from 20% to 100%.

If PWM control frequency is applied in the range from 1KHz to 20KHZ, The “non-linear” phenomenon on the Backlight Unit may be found.

So It's a suggestion that PWM control frequency should be less than 1KHz.

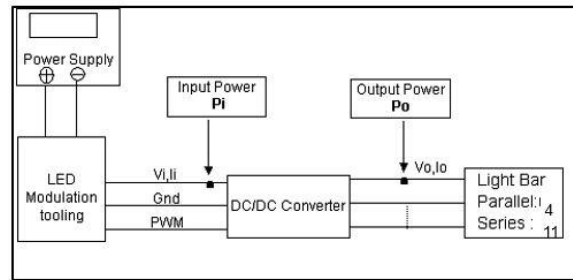

4. SIGNAL CHARACTERISTICS

4.1 Interface Timing

4.1.1 Timing Characteristics:

Signal	Item	Symbol	Min.	Typ.	Max.	Unit	Note	
LVDS Clock	Frequency	Fc	66.1	71	74.4		-	
	Period	Tc	13.4	14.1	15.1		-	
	Input cycle to cycle jitter	Trd	--	--	200		(a)	
	Input Clock to data skew	TLVCCS	-0.02*TC	--	0.02*TC		(b)	
	Spread spectrum modulation range	Fclkin_mod	--	--	1.02*Fc		(c)	
	Spread spectrum modulation frequency	FSSM	--	--	200			
		High Time	Tch		4/7	--		-
		Low Time	Tcl	--	3/7	--		-
Vertical Display Term	Frame Rate	Fr	--	60	--	Th	Tv=Tvd+Tvb	
	Total	Tv	810	823	830		-	
	Display	Tvd	800	800	800	Th	-	
	Blank	Tvb	10	23	30	Th	-	
Horizontal Display Term	Total	Th	1360	1440	1500	Tc	Th=Thd+Thb	
	Display	Thd	1280	1280	1280	Tc	-	
	Blank	Thb	80	160	220	Tc	-	

Note (1) Because this module is operated by DE only mode, Hsync and Vsync input signals should be set to low logic level or ground. Otherwise, this module would operate abnormally.

Note (2) The Tv(Tvd+Tvb) must be integer, otherwise, the module would operate abnormally.

INPUT SIGNAL TIMING DIAGRAM

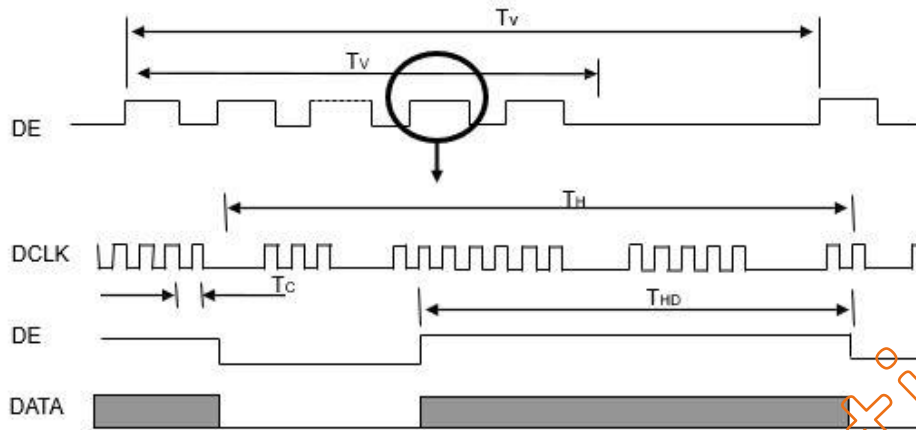

TIMING DIAGRAM of LVDS

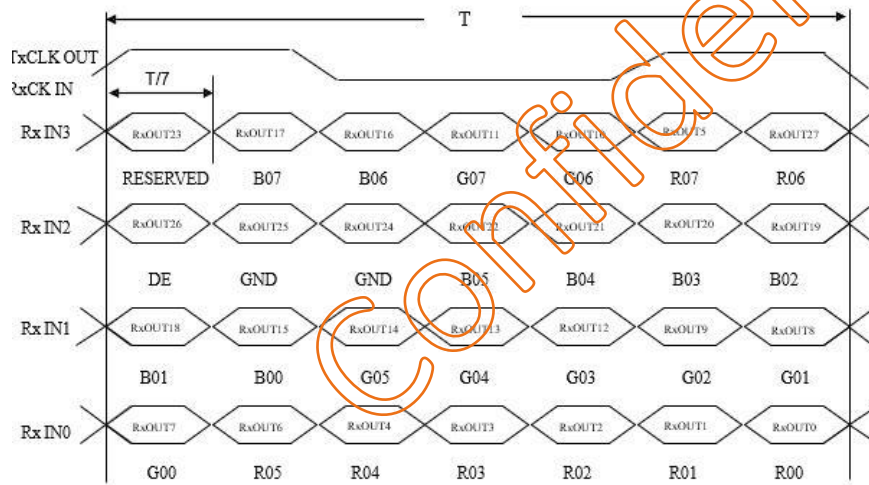

Note (a) The input clock cycle-to-cycle jitter is defined as below figures. $Trcl = |T_1 - T_1|$

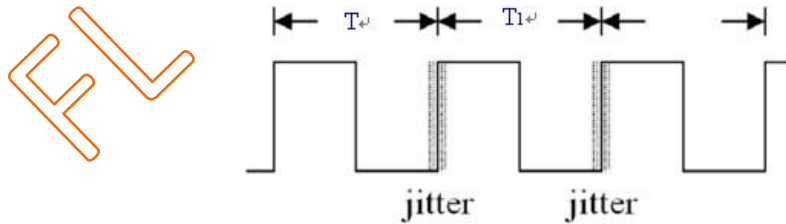

Note (b) Input Clock to data skew is defined as below figures

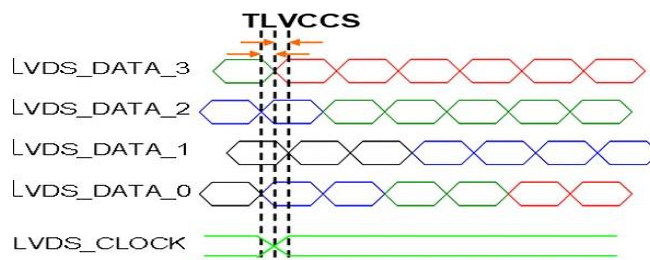

Note (c) The SSCG (Spread spectrum clock generator) is defined as below figures.

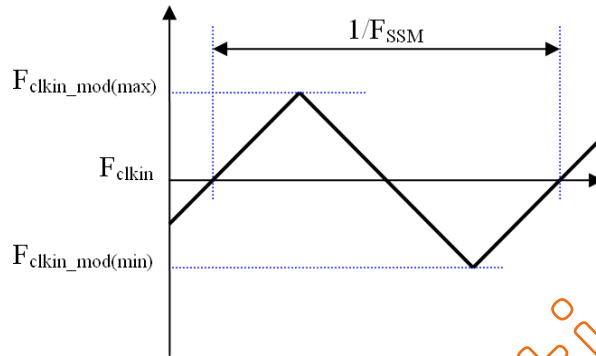

4.1.2 COLOR DATA INPUT ASSIGNMENT

The brightness of each primary color (red, green and blue) is based on the 6-bit gray scale data input for the color.

The higher the binary input, the brighter the color. The table below provides the assignment of color.

Color	Data Signal																	
	Red						Green						Blue					
	R5	R4	R3	R2	R1	R0	G5	G4	G3	G2	G1	G0	B5	B4	B3	B2	B1	B0
Basic Colors	Black	0	0	0	0	0	0	0	0	0	0	0	0	0	0	0	0	0
	Red	1	1	1	1	1	1	0	0	0	0	0	0	0	0	0	0	0
	Green	0	0	0	0	0	0	1	1	1	1	1	0	0	0	0	0	0
	Blue	0	0	0	0	0	0	0	0	0	0	0	1	1	1	1	1	1
	Cyan	0	0	0	0	0	0	1	1	1	1	1	1	1	1	1	1	1
	Magenta	1	1	1	1	1	1	0	0	0	0	0	0	1	1	1	1	1
	Yellow	1	1	1	1	1	1	1	1	1	1	1	0	0	0	0	0	0
	White	1	1	1	1	1	1	1	1	1	1	1	1	1	1	1	1	1
Gray Scale Of Red	Red(0)/Dark	0	0	0	0	0	0	0	0	0	0	0	0	0	0	0	0	0
	Red(1)	0	0	0	0	0	1	0	0	0	0	0	0	0	0	0	0	0
	Red(2)	0	0	0	0	1	0	0	0	0	0	0	0	0	0	0	0	0
	:	:	:	:	:	:	:	:	:	:	:	:	:	:	:	:	:	:
	:	:	:	:	:	:	:	:	:	:	:	:	:	:	:	:	:	:
	:	:	:	:	:	:	:	:	:	:	:	:	:	:	:	:	:	:
	Red(61)	1	1	1	1	0	1	0	0	0	0	0	0	0	0	0	0	0
	Red(62)	1	1	1	1	1	0	0	0	0	0	0	0	0	0	0	0	0
Red(63)	1	1	1	1	1	1	0	0	0	0	0	0	0	0	0	0	0	
Gray Scale Of Green	Green(0)/Dark	0	0	0	0	0	0	0	0	0	0	0	0	0	0	0	0	0
	Green(1)	0	0	0	0	0	0	0	0	0	0	1	0	0	0	0	0	0
	Green(2)	0	0	0	0	0	0	0	0	0	1	0	0	0	0	0	0	0
	:	:	:	:	:	:	:	:	:	:	:	:	:	:	:	:	:	:
	:	:	:	:	:	:	:	:	:	:	:	:	:	:	:	:	:	:
	:	:	:	:	:	:	:	:	:	:	:	:	:	:	:	:	:	:
	Green(61)	0	0	0	0	0	0	1	1	1	1	0	1	0	0	0	0	0
	Green(62)	0	0	0	0	0	0	1	1	1	1	1	0	0	0	0	0	0
Green(63)	0	0	0	0	0	0	1	1	1	1	1	1	0	0	0	0	0	
Gray Scale Of Blue	Blue(0)/Dark	0	0	0	0	0	0	0	0	0	0	0	0	0	0	0	0	0
	Blue(1)	0	0	0	0	0	0	0	0	0	0	0	0	0	0	0	0	1
	Blue(2)	0	0	0	0	0	0	0	0	0	0	0	0	0	0	0	0	1
	:	:	:	:	:	:	:	:	:	:	:	:	:	:	:	:	:	:
	:	:	:	:	:	:	:	:	:	:	:	:	:	:	:	:	:	:
	:	:	:	:	:	:	:	:	:	:	:	:	:	:	:	:	:	:
	Blue(61)	0	0	0	0	0	0	0	0	0	0	0	1	1	1	1	0	1
	Blue(62)	0	0	0	0	0	0	0	0	0	0	0	1	1	1	1	1	0
Blue(63)	0	0	0	0	0	0	0	0	0	0	0	1	1	1	1	1	1	

Note (1) 0: Low Level Voltage, 1: High Level Voltage

The brightness of each primary color (red, green and blue) is based on the 8-bit gray scale data input for the color. The higher the binary input, the brighter the color. The table below provides the assignment of color.

Color		Data Signal																							
		Red								Green						Blue									
		R7	R6	R5	R4	R3	R2	R1	R0	G7	G6	G5	G4	G3	G2	G1	G0	B7	B6	B5	B4	B3	B2	B1	B0
Basic Colors	Black	0	0	0	0	0	0	0	0	0	0	0	0	0	0	0	0	0	0	0	0	0	0	0	0
	Red	1	1	1	1	1	1	1	1	0	0	0	0	0	0	0	0	0	0	0	0	0	0	0	0
	Green	0	0	0	0	0	0	0	0	1	1	1	1	1	1	1	0	0	0	0	0	0	0	0	0
	Blue	0	0	0	0	0	0	0	0	0	0	0	0	0	0	0	1	1	1	1	1	1	1	1	1
	Cyan	0	0	0	0	0	0	0	0	1	1	1	1	1	1	1	1	1	1	1	1	1	1	1	1
	Magenta	1	1	1	1	1	1	1	1	0	0	0	0	0	0	0	0	1	1	1	1	1	1	1	1
	Yellow	1	1	1	1	1	1	1	1	1	1	1	1	1	1	1	0	0	0	0	0	0	0	0	0
	White	1	1	1	1	1	1	1	1	1	1	1	1	1	1	1	1	1	1	1	1	1	1	1	1
Gray Scale Of Red	Red(0) / Dark	0	0	0	0	0	0	0	0	0	0	0	0	0	0	0	0	0	0	0	0	0	0	0	
	Red(1)	0	0	0	0	0	0	0	1	0	0	0	0	0	0	0	0	0	0	0	0	0	0	0	
	Red(2)	0	0	0	0	0	0	1	0	0	0	0	0	0	0	0	0	0	0	0	0	0	0	0	
	⋮	⋮	⋮	⋮	⋮	⋮	⋮	⋮	⋮	⋮	⋮	⋮	⋮	⋮	⋮	⋮	⋮	⋮	⋮	⋮	⋮	⋮	⋮	⋮	
	⋮	⋮	⋮	⋮	⋮	⋮	⋮	⋮	⋮	⋮	⋮	⋮	⋮	⋮	⋮	⋮	⋮	⋮	⋮	⋮	⋮	⋮	⋮	⋮	
	Red(253)	1	1	1	1	1	1	0	1	0	0	0	0	0	0	0	0	0	0	0	0	0	0	0	
	Red(254)	1	1	1	1	1	1	1	0	0	0	0	0	0	0	0	0	0	0	0	0	0	0	0	
	Red(255)	1	1	1	1	1	1	1	0	0	0	0	0	0	0	0	0	0	0	0	0	0	0	0	
Gray Scale Of Green	Green(0) / Dark	0	0	0	0	0	0	0	0	0	0	0	0	0	0	0	0	0	0	0	0	0	0	0	
	Green(1)	0	0	0	0	0	0	0	0	0	0	0	0	0	0	1	0	0	0	0	0	0	0	0	
	Green(2)	0	0	0	0	0	0	0	0	0	0	0	0	0	1	0	0	0	0	0	0	0	0	0	
	⋮	⋮	⋮	⋮	⋮	⋮	⋮	⋮	⋮	⋮	⋮	⋮	⋮	⋮	⋮	⋮	⋮	⋮	⋮	⋮	⋮	⋮	⋮	⋮	
	⋮	⋮	⋮	⋮	⋮	⋮	⋮	⋮	⋮	⋮	⋮	⋮	⋮	⋮	⋮	⋮	⋮	⋮	⋮	⋮	⋮	⋮	⋮	⋮	
	Green(253)	0	0	0	0	0	0	0	0	1	1	1	1	1	1	0	1	0	0	0	0	0	0	0	
	Green(254)	0	0	0	0	0	0	0	0	1	1	1	1	1	1	0	0	0	0	0	0	0	0	0	
	Green(255)	0	0	0	0	0	0	0	0	1	1	1	1	1	1	1	0	0	0	0	0	0	0	0	
Gray Scale Of Blue	Blue(0) / Dark	0	0	0	0	0	0	0	0	0	0	0	0	0	0	0	0	0	0	0	0	0	0	0	
	Blue(1)	0	0	0	0	0	0	0	0	0	0	0	0	0	0	0	0	0	0	0	0	0	0	1	
	Blue(2)	0	0	0	0	0	0	0	0	0	0	0	0	0	0	0	0	0	0	0	0	0	1	0	
	⋮	⋮	⋮	⋮	⋮	⋮	⋮	⋮	⋮	⋮	⋮	⋮	⋮	⋮	⋮	⋮	⋮	⋮	⋮	⋮	⋮	⋮	⋮	⋮	
	⋮	⋮	⋮	⋮	⋮	⋮	⋮	⋮	⋮	⋮	⋮	⋮	⋮	⋮	⋮	⋮	⋮	⋮	⋮	⋮	⋮	⋮	⋮	⋮	
	Blue(253)	0	0	0	0	0	0	0	0	0	0	0	0	0	0	0	1	1	1	1	1	1	1	0	
	Blue(254)	0	0	0	0	0	0	0	0	0	0	0	0	0	0	0	1	1	1	1	1	1	1	0	
	Blue(255)	0	0	0	0	0	0	0	0	0	0	0	0	0	0	0	1	1	1	1	1	1	1	1	

Note: 0: Low Level Voltage, 1: High Level Voltage

4.2 Power ON/OFF Sequence

To prevent a latch-up or DC operation of LCD assembly, the power on/off sequence should be as the diagram below.

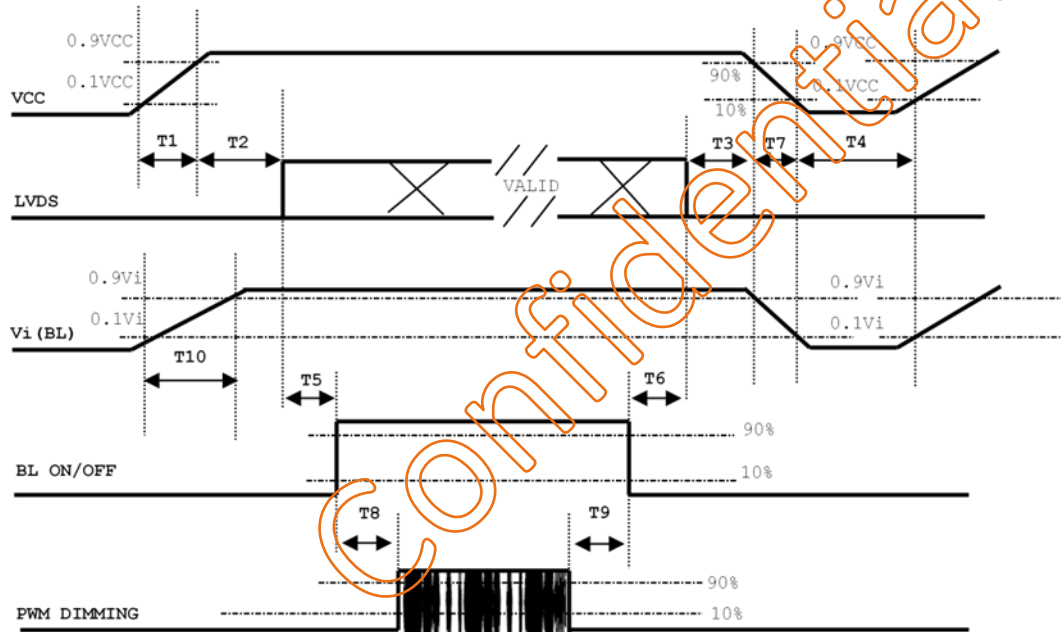

Note:

- (1) The supply voltage of the external system for the module input should be the same as the definition of Vcc.
- (2) When the backlight turns on before the LCD operation of the LCD turns off, the display may momentarily become abnormal screen.
- (3) In case of VCC = off level, please keep the level of input signals on the low or keep a high impedance.
- (4) T4 should be measured after the module has been fully discharged between power off and on period.
- (5) Interface signal shall not be kept at high impedance when the power is on.
- (6) INX won't take any responsibility for the products which are damaged by the customers not following the Power Sequence.
- (7) There might be slight electronic noise when LCD is turned off (even backlight unit is also off). To avoid this symptom, we suggest "Vcc falling timing" to follow "T7 spec".

Parameter	Value			Units
	Min	Typ	Max	
T1	0.5	---	10	ms
T2	0	---	50	ms
T3	0	---	50	ms
T4	500	---	---	ms
T5	450	---	---	ms
T6	200	---	---	ms
T7	10	---	100	ms
T8	10	---	---	ms
T9	10	---	---	ms
T10	20	---	50	ms

4.3 The Input Data Format

SEL 6/8="Low" for 6 Bits LVDS

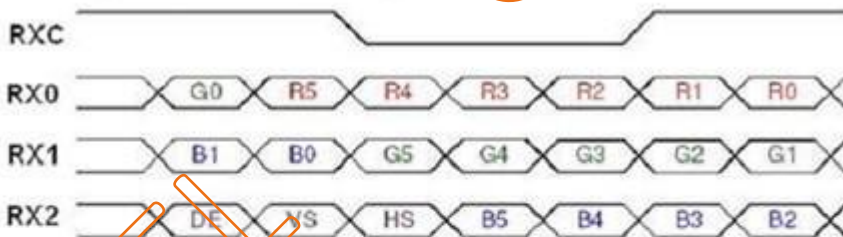

SEL 6/8="High" for 8 Bits LVDS

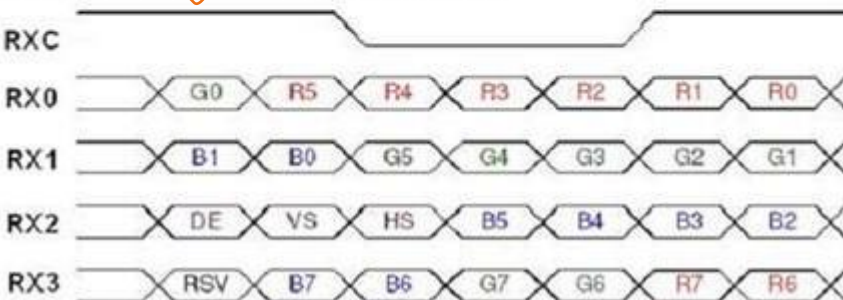

Note (1) R/G/B data 7: MSB, R/G/B data 0: LSB

Note (2) Please follow PSWG

Signal Name	Description	Remark
R7	Red Data 7 (MSB)	Red-pixel Data Each red pixel's brightness data consists of these 8 bits pixel data.
R6	Red Data 6	
R5	Red Data 5	
R4	Red Data 4	
R3	Red Data 3	
R2	Red Data 2	
R1	Red Data 1	
R0	Red Data 0 (LSB)	
G7	Green Data 7 (MSB)	Green-pixel Data Each green pixel's brightness data consists of these 8 bits pixel data.
G6	GreenData 6	
G5	GreenData 5	
G4	GreenData 4	
G3	GreenData 3	
G2	GreenData 2	
G1	GreenData 1	
G0	GreenData 0 (LSB)	
B7	Blue Data 7 (MSB)	Blue-pixel Data Each blue pixel's brightness data consists of these 8 bits pixel data.
B6	Blue Data 6	
B5	Blue Data 5	
B4	Blue Data 4	
B3	Blue Data 3	
B2	Blue Data 2	
B1	Blue Data 1	
B0	Blue Data 0 (LSB)	
RXCLKIN+ RXCLKIN-	LVDS Clock Input	
DE	Display Enable	
VS	Vertical Sync	
HS	Horizontal Sync	



5. INTERFACE PIN DESCRIPTION

5.1 LCM Connector PIN Assignment

	Symbol	Description	Note
1	12V	LED Power	-
2	12V	LED Power	-
3	12V	LED Power	-
4	12V	LED Power	-
5	ENLED	Enable pin	(3)
6	DIMMING	Backlight Adjust	(3)
7	NC	No Connection or Ground	
8	NC	No Connection or Ground	
9	VCC	Power supply: +3.3v	-
10	VCC	Power supply: +3.3v	-
11	GND	Ground	
12	GND	Ground	-
13	RX0-	LVDS Differential Data Input (Negative) 0	-
14	RX0+	LVDS Differential Data Input (Positive) 0	-
15	GND	Ground	-
16	RX1-	LVDS Differential Data Input (Negative) 1	-
17	RX1+	LVDS Differential Data Input (Positive) 1	-
18	GND	Ground	-
19	RX2-	LVDS Differential Data Input (Negative) 2	-
20	RX2+	LVDS Differential Data Input (Positive) 2	
21	GND	Ground	
22	RXCLK-	Negative of clock	
23	RXCLK+	Positive of clock	
24	GND	Ground	
25	RX3-	LVDS Differential Data Input (Negative) 3	
26	RX3+	LVDS Differential Data Input (Positive) 3	
27	GND	Ground	
28	SEL6/8	LVDS 6/8 bit select function control, Low-> 6 bit input mode High->8 bit input mode	(2)(3)
29	GND	Ground	
30	NC	No Connection or Ground	

Note (1) Connector Part No.: P2 187114-30091

Note (2) "Low" stands for 0V. "High" stands for 3.3V

Note (3) ENLED(BLON), Dimming(E_PWM), SEL6/8 as shown below

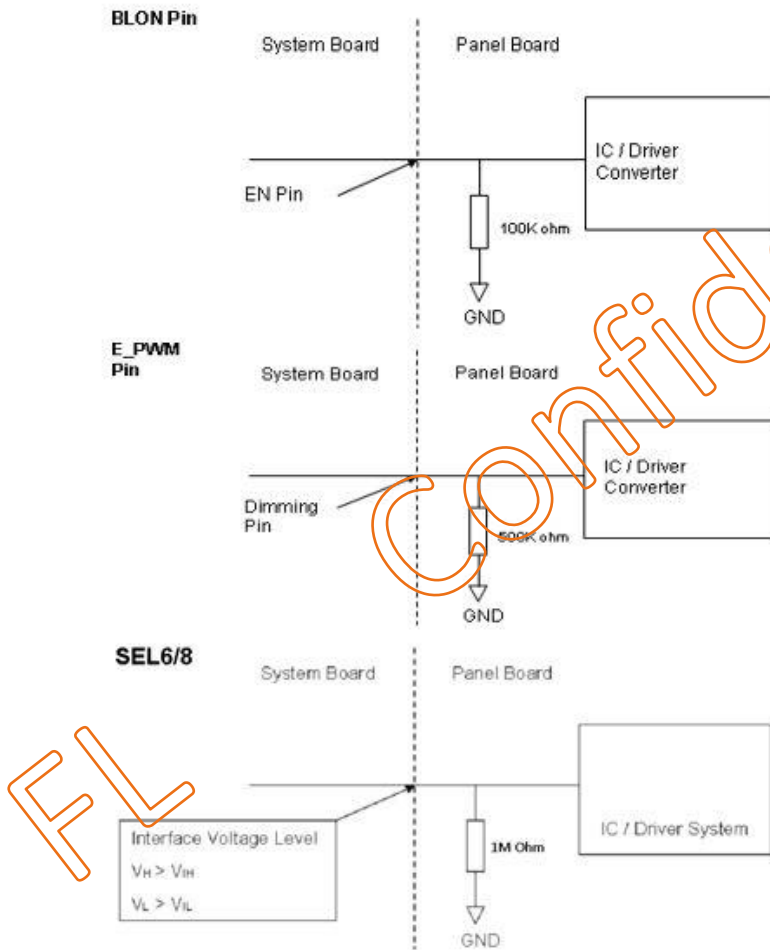

6. BLOCK DIAGRAM

The following diagram shows the functional block of the TFT module:

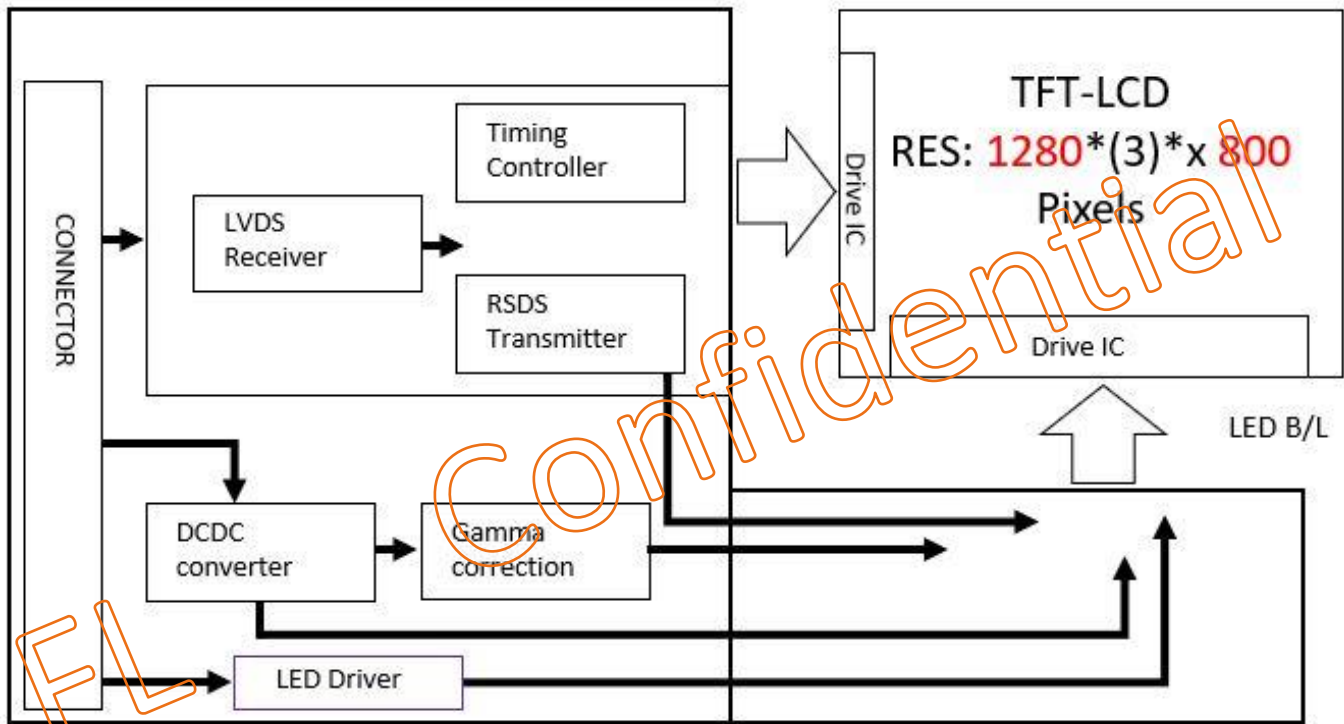

7. OPTICAL CHARACTERISTIC

The optical characteristics are measured under stable conditions at room temperature.

Item		Symbol	Condition	Min.	Typ.	Max.	Unit	Note		
Contrast Ratio		CR	Viewing angle at normal direction $\theta_x=0^\circ, \theta_y=0^\circ$	800	1000	-	-	(2)(5)		
Response Time		T_R		-	12	17	ms	(3)		
		T_F		-	8	13	ms			
Center Luminance of White		L_c		480	600	-	cd/m ²	(4)(5)		
White Variation		δW		-	1.25	1.4	-	(5)(6)		
Chromaticity	Red	R_x		Viewing angle at normal direction $\theta_x=0^\circ, \theta_y=0^\circ$	Typ.	0.652	Typ.	-	(1) (5)	
		R_y				0.338		-		
	Green	G_x				0.326		-		
		G_y				0.608		-		
	Blue	B_x				-0.05		0.150		+0.05
		B_y	0.053			-		-		
	White	W_x	0.313			-		-		
		W_y	0.329			-		-		
Viewing Angle	Horizontal	θ_{x+}	CR \geq 10	80	88	-	Deg.	(1)(5)		
		θ_{x-}		80	88	-				
	Vertical	θ_{y+}		80	88	-				
		θ_{y-}		80	88	-				

The following optical specifications shall be measured in a darkroom or equivalent state (ambient luminance <2 lux, and at room temperature).

The room temperature is 25°C \pm 2°C

Note 1: Definition of Viewing Angle

Viewing angle is the angle at which the contrast ratio is greater than 10. The viewing angles are determined for the horizontal or the vertical clock direction with respect to the optical axis which is normal to the LCD surface

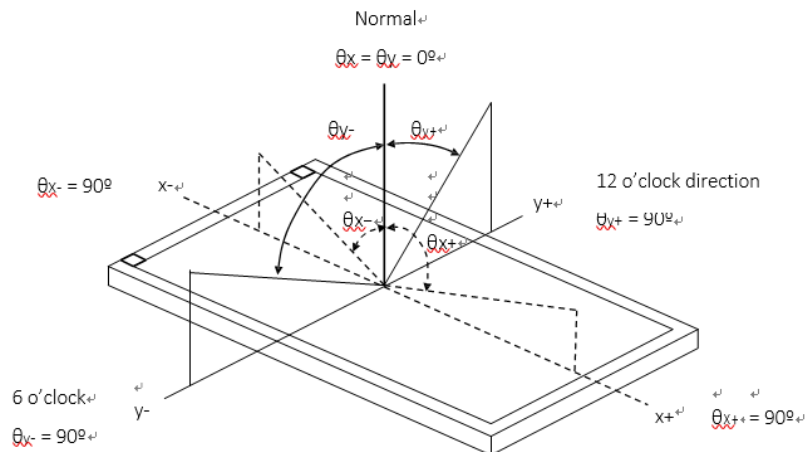

Note 2: Definition of Contrast Ratio (CR)

Measure the viewing angle of $\Theta = 0$ and at the center of the LCD surface. Luminance with all pixels in white state divide by Luminance with all pixels in Black state

Note 3 Definition of Response Time:

The response time is set initially by defining the “Rising Time (T_r)” and the “Falling Time (T_f)” respectively. The response time interval is between 10% and 90% of amplitudes, please refer the figure to the followings:

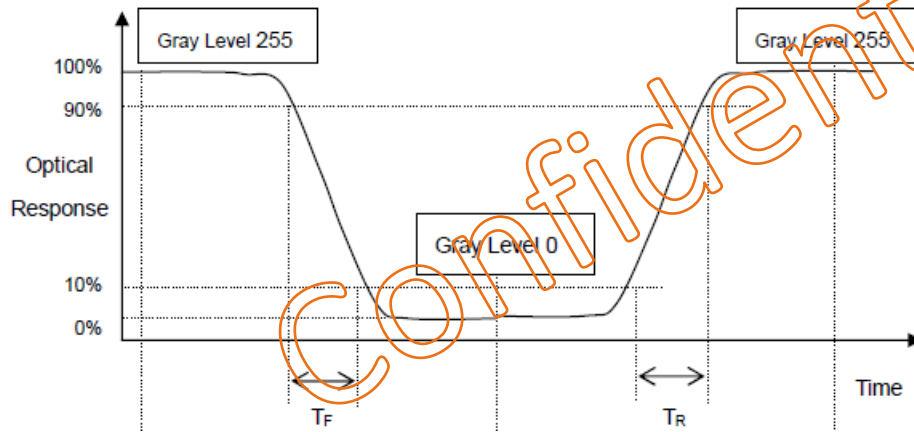

Note 4: Definition of Brightness (Lc)

Measure the center area of the panel and the viewing angle of the $\theta_x = \theta_y = 0^\circ$

Note 5: The method of optical measurement:

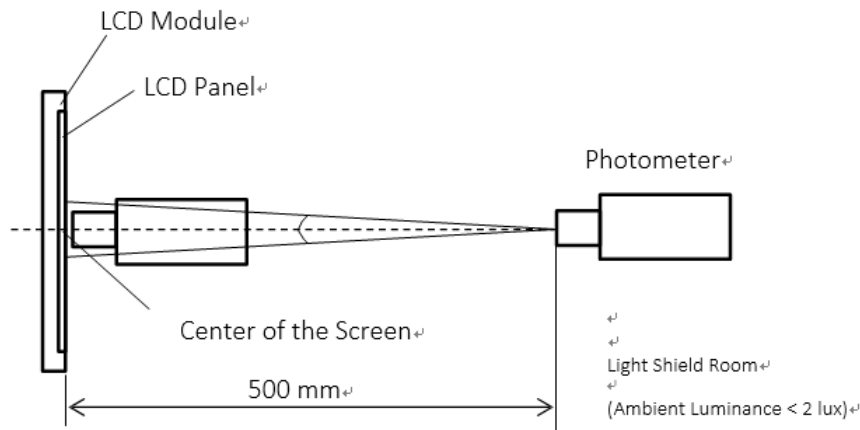

Note 6: Definition of White Variation (δW):

Measure the luminance of gray level 255 at 9 points

$$\delta W = \text{Maximum [L (1), L (2), L (3)...L (8), L (9)]} / \text{Minimum [L (1), L (2), L (3)... L (4), L (5)]}$$

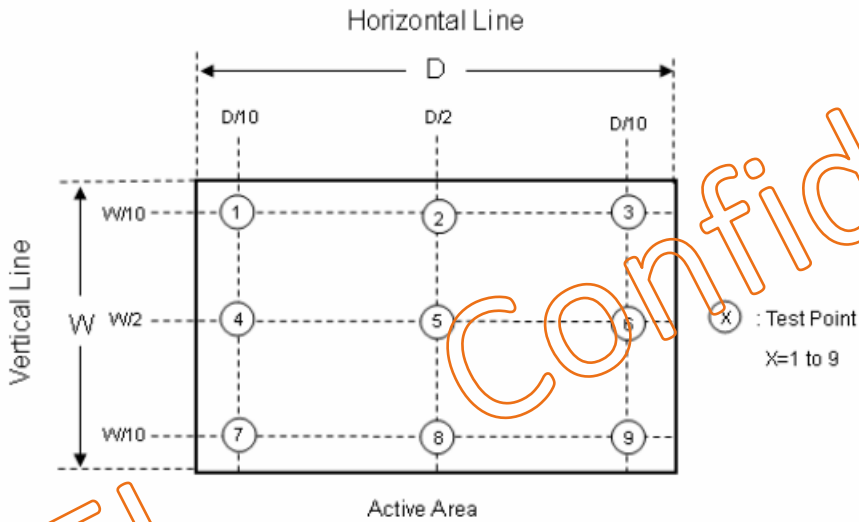

FL

B. Touch Screen specification

1. Environmental Specification

Specification	Value	Remarks
Operating Temperature	-30°C ~ 80°C	
Storage Temperature	-40°C ~ 80°C	
Operating Humidity	20% ~ 90%RH	
Storage Humidity	10% ~ 90%RH	

2. Mechanical Specification

Specification	Value
Operating Life (Finger input)	10 ⁷ times
Light Transmittance	>86% Min. (JIS K-7105) with glass
Surface hardness	Depending by the cover Lens Material Customer choose
FPC Peeling Force	5N Max

3. COMBO Type Controller

Parameters	Features
Circuit Board Dimension	Refer to drawings
Channels of Panel	Based on Sensor Design
Input Voltage	3.5V~5.5V Typical 5V for USB suggest to use 5V for I2C too
Linearity(Note 1)	Single Line drawing accuracy : Up to 1pt +/- 1mm offset /10mm
	Single Touch (point) accuracy : Up to 1pt +/- 1mm
Interface	USB: 2.0(Below) Full Speed I2C:100K/400K Hz
Resolution	4096x4096 resolution
Power consumption(mA)	Active Mode: <108mA
	Idle Mode : <54mA
	Sleep Mode :< 10mA
	(Operation Mode :Active Mode only)
Report rate(points/sec) Note(2)	> 100 Hz
Response time	Average < 25 ms



Note (1): Depending by Sensor design and other parameters, Refer to Windows 8 Logo regulation if need to follow min spec

Note (2): Report rate will vary by channel number, cover thickness, number of fingers and other parameters.

9. DIMENSION AND DRAWING

FL

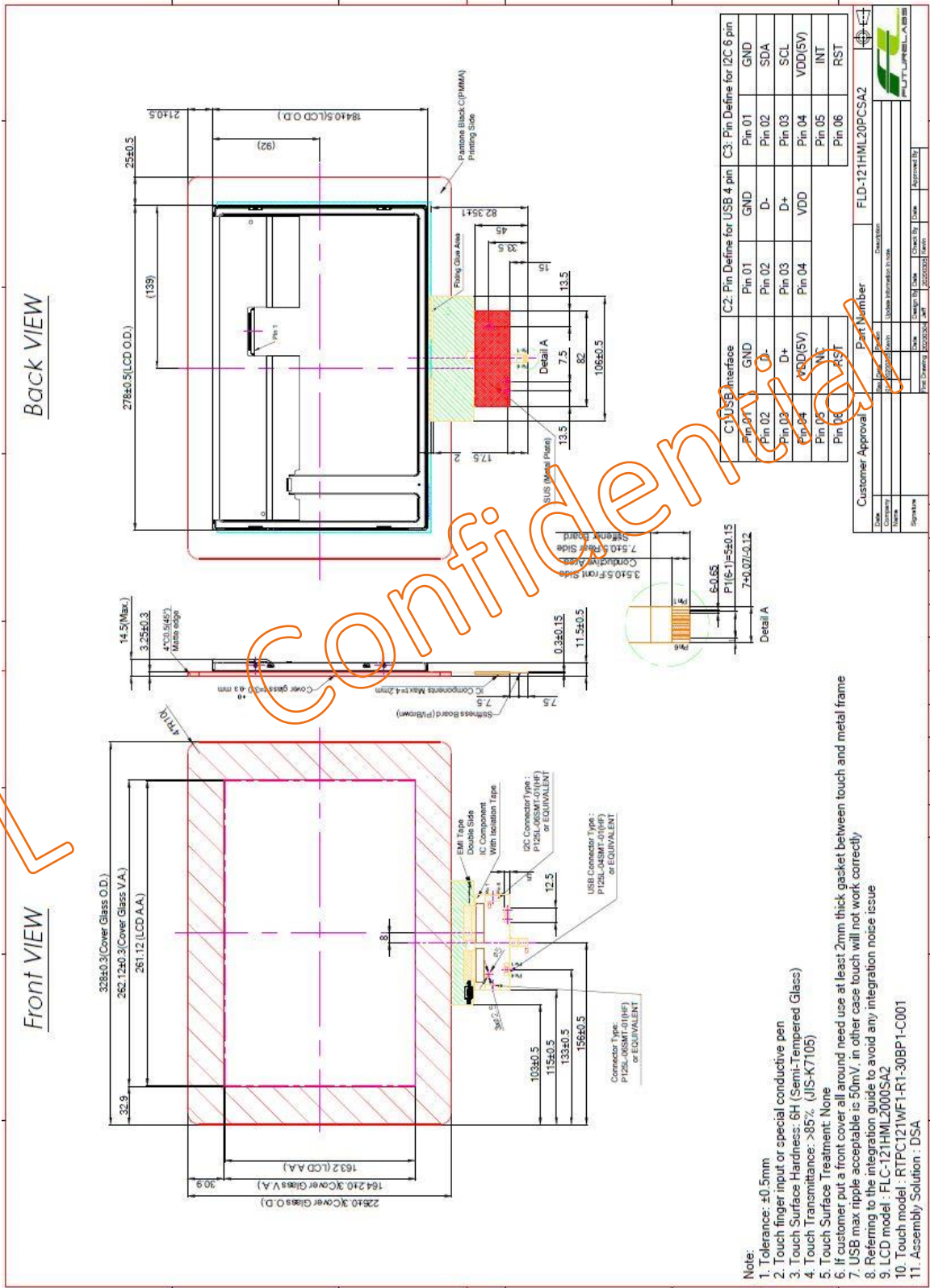

- Note:**
1. Tolerance: ±0.5mm
 2. Touch finger input or special conductive pen
 3. Touch Surface Hardness: 6H (Semi-Tempered Glass)
 4. Touch Transmittance: >85% (JIS-K7105)
 5. Touch Surface Treatment: None
 6. If customer put a front cover all around need use at least 2mm thick gasket between touch and metal frame
 7. USB max ripple acceptable is 50mV, in other case touch will not work correctly
 8. Referring to the integration guide to avoid any integration noise issue
 9. LCD model: FLC-121HML2000SA2
 10. Touch model: RTPC121WF1-R1-30BP1-C001
 11. Assembly Solution: DSA

10. PRECAUTION AND PRODUCT HANDLING

- Do not apply the external force such as bending or twisting to the LCD panel and backlight during assembly.
- Do not insert and plug out the input connector while the LCD panel is operating.
- Do not take apart the panel or frame from LCD module assembly or insert anything into the backlight unit.
- Do not keep the same pattern in a long period of time, it may cause image sticking on LCD panel. Can use shuffle content periodically if fixed pattern is displayed on the screen.
- Do not touch the display area with bare hands, this will stain the display area.
- Pay attention to handle lead wire of backlight, that is not tugged in connect with LED driver.
- Do not change variable resistance settings in LCD panel, it may cause not satisfy of LCD characteristics specification.
- The surface of LCD panel's polarizer is very soft and easily scratched, please use a very soft dry cloth without chemicals for cleaning.
- To avoid the static electricity to damage the CMOS LSI, the operator should be grounded when in contact with the LCD panel, and also to all electrical equipment.
- Need to follow the correct power frequency when LCD panel is connecting and operating, this can avoid damage to CMOS LSI during latch-up.
- Need to store the LCD panel indoor without the exposure of sunlight where the temperature is $25^{\circ}\text{C} \pm 5^{\circ}\text{C}$ and the humidity is below 60% RH.

